

Persona[®] Primary Knee:

Flexion-First Balancing Instrumentation

Surgical Technique



Table of Contents

Introduction	1
Preparation of the Femur	2
Sizing the Femoral Component	3
Check Tibial Resection	3
Anterior Referencing	5
Setting Femoral Rotation and Ligament Tension	6
Drill, Pin and Position the A/P Cut Block	7
Check the Femoral Rotation with the FuZion Tensor- Second Option for Rotation Check	8
Preliminary Check of the Flexion Gap	10
AP Femoral Resection	11
Distal Femoral Resection	12
Checking the Flexion Gap	14
Extension Gap	16
Extension Gap- Check FuZion® Tensor Options	17
Checking the Alignment	17
Options to Correct AP Block Rotation & Positioning	21
Chamfer Cuts	24

Introduction

Successful total knee arthroplasty depends in part on re-establishment of normal lower extremity alignment, proper implant design and orientation, secure implant fixation, and adequate soft tissue balancing and stability. Persona The Personalized Knee[®] is designed to help the surgeon accomplish these goals by combining alignment accuracy with a simple, straight-forward technique.

The Flexion First Balancing Instruments are designed to help accomplish these goals by providing the surgeon with dynamic ligament feedback.

The Flexion First Balancing Instruments were specifically designed to provide crossover utility, harmonizing measured resection and gap balancing philosophies. This surgical technique describes the use of the Flexion First Balancing Instruments in common surgical workflows, used in conjunction with the Persona[®] Primary Instruments.

Surgical Sequence

1. Resect the proximal tibia in preferred order (#97-5026-001-00).
2. Use the Flexion First Balancing Instruments to establish the joint tension, while evaluating limb alignment in extension and flexion to allow for gap balancing (#2750.2-GLBL).
3. Complete procedure, use Persona Primary Instruments to complete the procedure. (#97-5026-001-00).



Figure 1



Figure 2



Figure 3



Figure 4

Preparation of the Femur

Prepare proximal tibia in the normal fashion, according to the standard Persona Primary Knee Surgical and the desired constraint level. Use the 8 mm IM Drill to drill a hole in the center of the patellar sulcus of the distal femur making sure that the drill is parallel to the shaft of the femur in both the anteroposterior and lateral projections (Figure 1). The hole should be approximately one-half to one centimeter anterior to the origin of the posterior cruciate ligament. Medial or lateral displacement of the hole may be needed according to preoperative templating of the A/P radiograph.

Pull the lever on the modular handle and insert the IM rod (Figure 2). Orientation of the IM rod will align with the polished line on the sides of the modular handle.

Insert the IM Rod into the medullary canal. The Handle with Quick Connection will facilitate insertion (Figure 3). Remove the Persona Modular Handle (Figure 4).

⊖ **Technique Tip:** Drill to end of the first diameter on the drill bit in order to prevent over-drilling (Figure 1).

00-5978-014-00



110040836



42-5099-014-00





Figure 5



Figure 6



Figure 6a

Sizing the Femoral Component

Determine the size of the femoral component in the A/P direction. Assemble the femoral sizing instrument on the intramedullary alignment rod to determine the A/P dimension of femoral component (Figure 5).

Both feet of the femoral sizing instrument must have good contact with the posterior condyles. The point of the stylus should rest on the anterior femoral cortex.

Place the point of the stylus on the deepest point of the anterior femoral cortex above the edge of the cartilage in order to obtain optimal measurement. The size of the femoral component is read on the vertical scale. In the case of intermediate sizes, choose the smaller size.

When the proximal tibial bone has been removed, resect any remaining meniscus and bone fragment. Remove femoral and tibial osteophytes. Take care to remove any remaining posterior osteophytes.

Check Tibial Resection

Insert the Flexion Balancing Tibial Spacer Block to ensure that enough tibial bone has been removed (Figure 6). Insert the Alignment Rod to the Spacer Block to check that the tibial cut is perpendicular to the longitudinal axis of the tibia (Figure 6a). If you want to do a release, do so at this step of the technique.

☰ Technique Tip: Remove all the osteophytes on the femur at this stage. Osteophytes can impact ligament tension. Ensure all osteophytes are removed prior to assessing ligament balancing.

110040835



110040836



110040920



00-5785-080-00





Figure 7



Figure 8

The A/P cut block is chosen based on the previously determined size of the femoral component. The angle guide for femoral with the predetermined valgus angle is inserted into the A/P cut block. The arrow on the angle guide for femoral should point to the side to be operated on, i.e. “right” or “left.” The switch must be in the “open” position when the femoral angle guide is inserted (Figure 7).

There are five femoral angle guides: 4°, 5°, 6°, 7° and 8°. Each angle guide should correspond to the valgus angle α (angle between the mechanical axis and anatomical femoral axes), which is determined prior to the surgery. The valgus angle is usually around 6°. If the angle α is between two bushing angles, select the next smaller angle for a genu varum or the next larger angle for the genu valgum.

Slide the prepared A/P cut block onto the intramedullary alignment rod (Figure 8).

☰ **Technique Tip:** Generally, in a varus knee, a femoral angle α of 4°–6° is preferred. In the case of a valgus knee, an angle of 6°–8° is preferred. This makes the balancing of the ligaments easier and corresponds to the individual anatomical conditions of the knee joint in question.

☰ **Note:** There are 12 A/P cut block sizes, ranging from size 1 to 12.

110040836



110040853



110040858





Figure 9

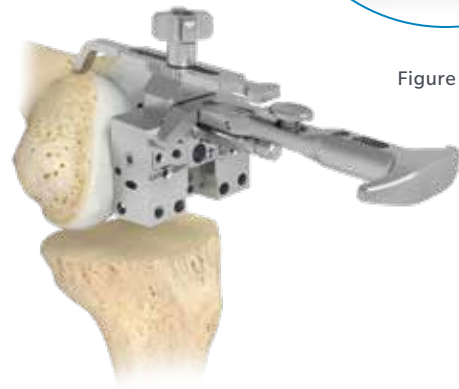

Figure 10

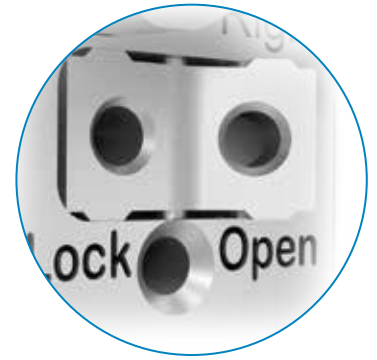

Figure 10a

Anterior Referencing

Attach the anterior Femoral Feeler Guide to the A/P cut block (Figure 9). Position the stylus feeler on the deepest point of the anterior femoral cortex above the edge of the cartilage, and lock the switch on AP cut block in this position (Figures 10 and 10a).

Femoral rotation should now roughly aligned to the epicondylar axis or the anterior posterior femoral axis.

Now the Femoral Feeler Guide can be removed.

110040859



110040858



110040853



110040836



42-5399-017-00





Figure 11

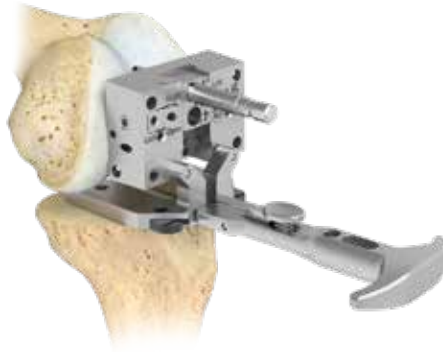

Figure 12



Figure 13



Figure 14

Setting Femoral Rotation and Ligament Tension

The desired external rotation of the A/P cut block of about 3° is usually obtained automatically through the correct balance and tension of the ligament system (Figure 11). The femoral rotation guide is inserted into the A/P cut block (Figure 12).

In order to have a stable support on the cut tibia, use the 10 mm color-coded black spacer. The gap corresponds to the smallest overall tibial height of 10 mm, and represents the flexion gap. With the aid of two Steinmann pins inserted laterally in the A/P cut block, the rotation can also be checked via the epicondylar axis (Figure 14).

ⓘ **Note:** Start with the 10 mm spacer, which is color-coded black (Figure 12). The spacers come in

1 mm thicknesses from 10 mm–14 mm, followed by 16 mm, 18 mm and 20 mm thickness (Figure 13).

ⓘ **Technique Tip:** If the femoral rotation guide cannot be inserted due to too high tension of the ligament system, the tibia must be resected again with the aid of the tibial cut block. This can be shifted by 2 mm increments by utilizing the adjacent line of holes.

ⓘ **Technique Tip:** If the ligament tension is insufficient, tibial augmentation plates with the same thickness must be inserted on the underside with the femoral rotation guide medially and laterally until the desired ligament tension is achieved.

110040860



110040853



110040858



110040836



110040926



110040867



42-5399-017-00





Figure 16a

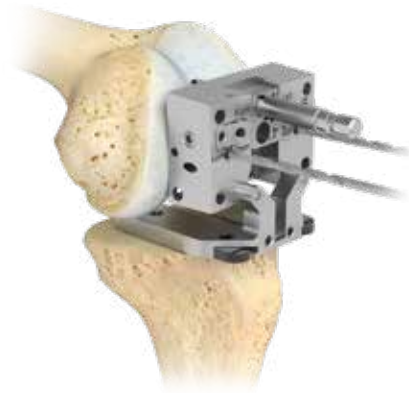

Figure 15



Figure 16

Drill, Pin and Position the A/P Cut Block

Drill and pin the A/P cut block into the two countersunk holes using standard 3.2 mm pins (Figures 15 and 16). After this, remove the femoral rotation guide with the modular handle.

Check the resection height with the resection gauge in order to prevent anterior notching (Figure 16a). Anterior notching may weaken the anterior cortex.

00-5120-085-00



00-5901-020-00



00-5977-084-00





Figure 17

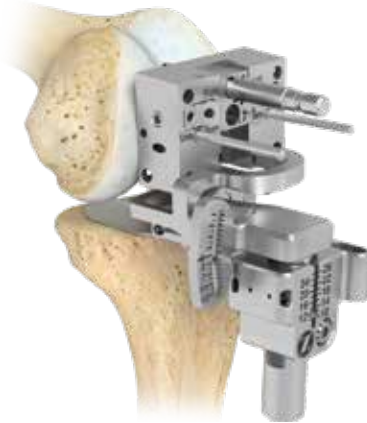

Figure 18

Check the Femoral Rotation with the FuZion Tensor - Second Option for Rotation Check

Assemble the FuZion Tensor (Figure 17).

Insert the FuZion Tensor assembly into the cut block (Figure 18).

110040877



42-5097-021-00



42-5097-021-01



110040853



110040858



110040836



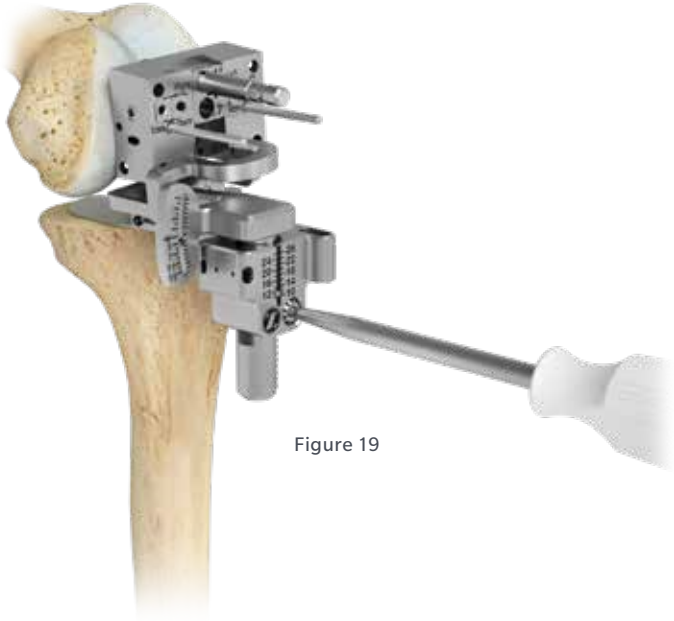

Figure 19



Figure 20

Use a 3.5 mm hex driver to adjust the tensor. Start with 10 mm to assess the flexion gap. If more tension is needed, use the 3.5 mm hex driver to adjust tension. Once the appropriate tension is achieved, the rotation can be read on the scale (Figure 19). The correction of the AP block rotation and positioning should be executed before the AP femoral resection (Options Figure 51–66).

After final placement of the desired anterior referencing A/P cut block, insert two additional 3.2 mm trocar-tipped pins or 3.2 mm headed screws (Figure 20).

⊖ **Technique Tip:** The angle scale on the medial side of the instrument should read 0° on this step (Figure 19).



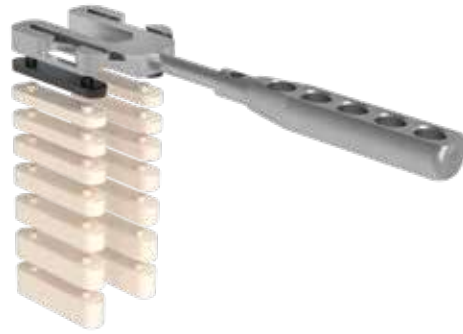

Figure 22

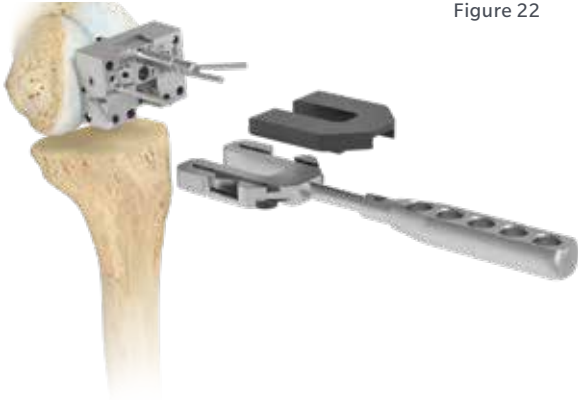

Figure 21



Figure 23

Preliminary Check of the Flexion Gap

As a final check prior to making the A/P cuts, use the Tibial Plate Handle and attach the femoral distance plate. The gap corresponds to the smallest overall tibial height of 10 mm, and confirm appropriate tension and femoral rotation (Figure 21 and Figure 23). The correction of the AP block rotation and positioning should be executed before the AP femoral resection (Options Figure 51–66).

ⓘ **Note:** Start with the 10 mm spacer, which is color coded black (Figure 22). The spacers come in 1 mm thicknesses from 10 mm–14 mm, followed by 16 mm, 18 mm and 20 mm thickness (Figure 22).

110040871



110040870



110040926



110040867





Figure 24

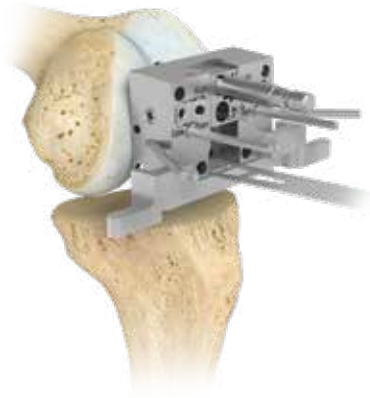

Figure 25

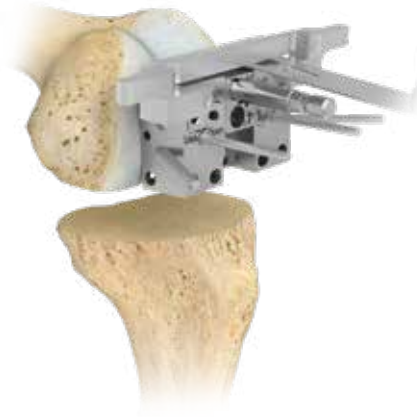

Figure 26

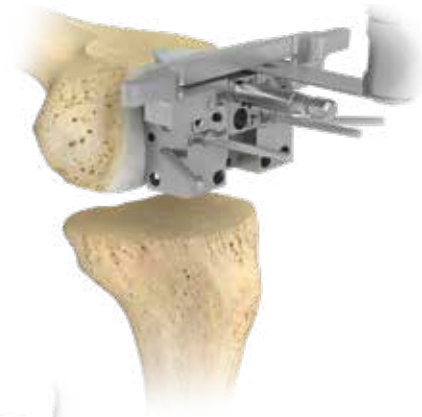

Figure 27

AP Femoral Resection

Attach saw blade guide to the posterior portion of the cut block (Figure 24).

Resect the posterior condyles. Remove saw blade guide following the resection. (Figure 25).

Attach saw blade guide to the anterior portion of the cut block (Figure 26).

Then, perform the anterior resection (Figures 24–27). This completes the AP resection.



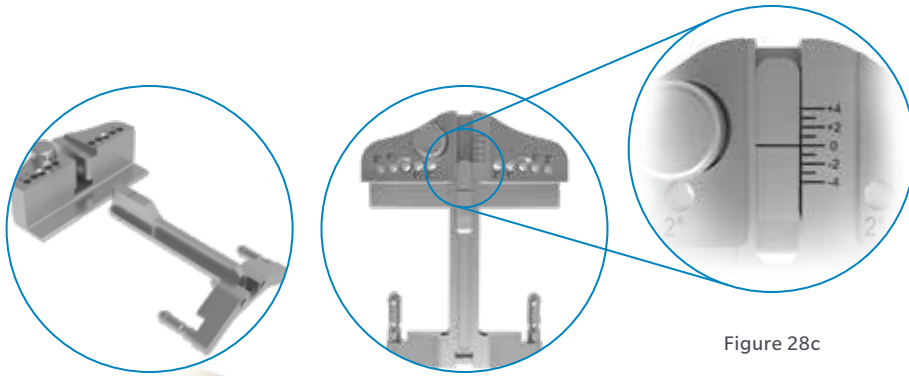

Figure 28a

Figure 28b

Figure 28c

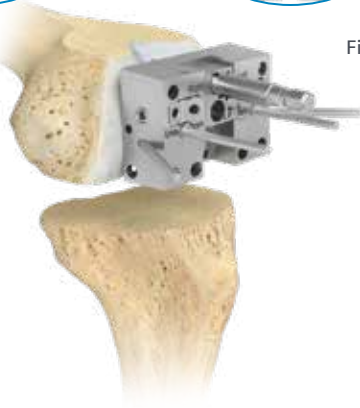

Figure 28

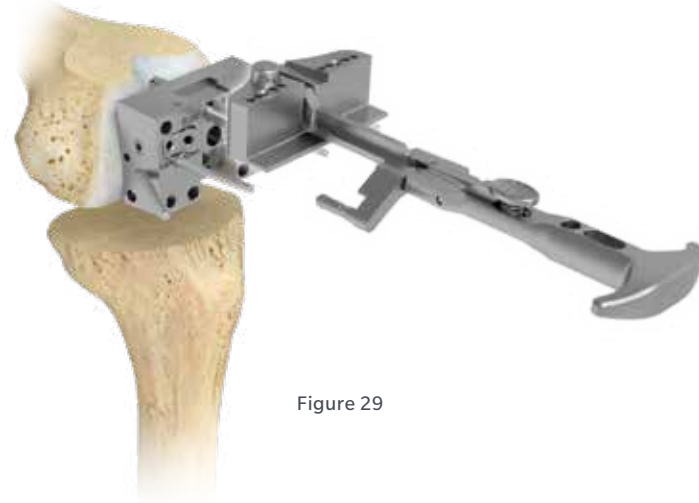

Figure 29

Distal Femoral Resection

Figure 28 shows the AP resection is now complete.

Connect distal cut guide handle to distal cut guide base (Figure 28a).

Lock the handle in the 0 position (Figures 28b and 28c).

After connecting the distal cut guide handle to the distal cut guide base, connect the Persona Handle to the distal cut guide handle (Figure 29).

🔑 **Technique Tip:** Remove posterior osteophytes on the femoral condyles and, if necessary, release the posterior capsule before making the distal femoral cut. This eases the assessment of the correct position for depth of the distal femoral resection. This procedure is especially important in the case of a severe flexion contracture.

110040838

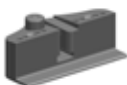

110040837



42-5399-017-00



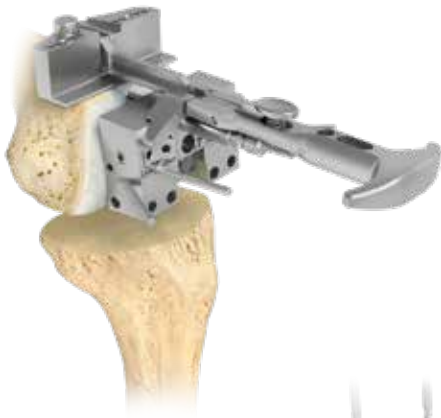

Figure 30

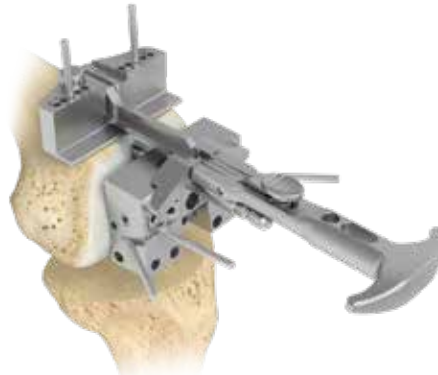

Figure 32

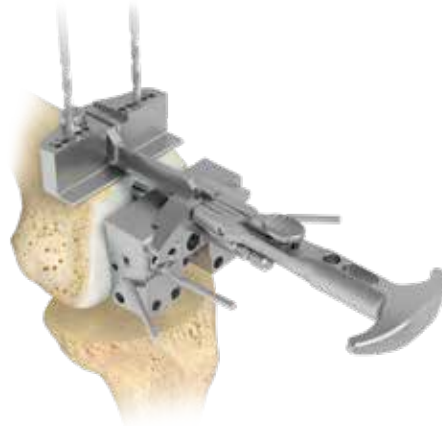

Figure 31



Figure 33

Assemble the distal cut guide to the A/P cut block using the handle (Figure 30).

Drill and pin the distal cut guide base in place in the two countersunk holes in the distal cut guide base using standard 3.2 mm pins (Figures 31–33). Once distal cut guide base is secure, remove the distal cut guide handle with using the sizing plate handle by pressing the button on the distal cut guide base and by pulling the sizing plate handle distally. Then remove the two trocar pins, the A/P cut guide, and the two pins and the intramedullary alignment rod (Figure 32).



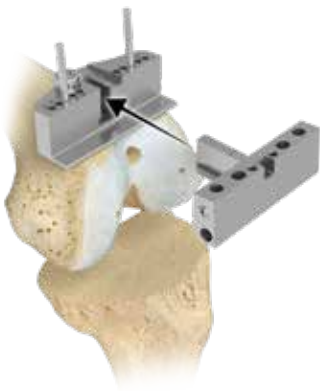

Figure 34



Figure 34a

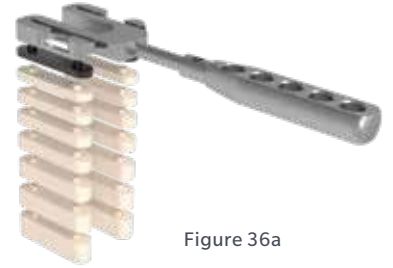

Figure 36a



Figure 35

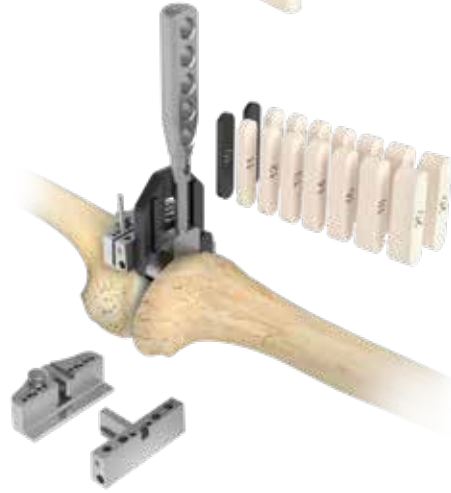

Figure 36

Checking the Extension Gap

Now assemble the distal cut guide to the distal cut guide base. Lock the distal cut guide in the 0 position (Figures 34 and 34a). Place the femoral distance plate and the tibial spacer plate together to form the distance gauge. Check the extension gap with the distance gauge (Figures 36 and 36a). The distance corresponds to the smallest overall tibial height of 10 mm, and confirm appropriate tension.

ⓘ **Technique Tip:** If the alignment guide shows a deviation from the middle of the upper ankle joint, the position of the femoral resection cut block must be corrected (Figures 35a, 35b, 35c). A correction of 1° or 2° is made possible by using the 2° femoral correction block. For a larger deviation, the femoral resection cut block must be re-positioned.



Figure 35a

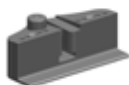

Figure 35b



Figure 35c

110040838



110040839



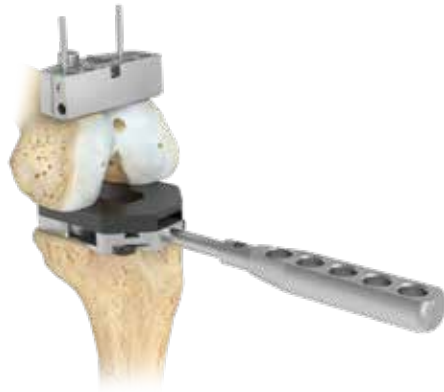

Figure 37

Checking the flexion and extension gap, mate the femoral distance plate and the tibial spacer plate. The flexion gap is checked using this distance gauge. The distance gauge without the spacers corresponds to the smallest overall tibial height of 10 mm (Figure 37).

The distal cut guide can be shifted proximally or distally by 1 mm increments if adjustments are necessary (Figure 34a).



Figure 38

Extension Gap

Slide Femoral Distance Plate anteriorly so it contacts the distal cut guide. The Tibial Distance Plate should still rest on the proximal tibia. Shim to achieve appropriate tension/stability (Figure 38).

ⓘ **Note:** The spacers come in 1 mm thicknesses from 10 mm–14 mm, followed by 16 mm, 18 mm and 20 mm thickness (Figure 38).

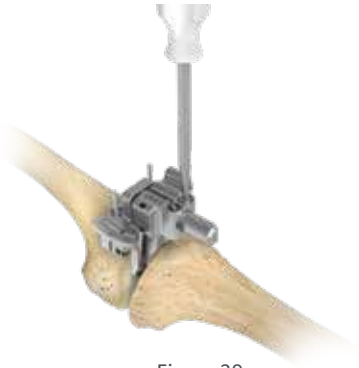

Figure 39



Figure 40



Figure 41



Figure 42

Extension Gap - Check FuZion Tensor Option

Using the FuZion Tensor assembly and 3.5 mm hex driver, distract the joint until appropriate tension is achieved (Figures 39 and 40). Insert the Persona handle into the distal cut block (Figure 41).

Perform alignment check using the alignment rod (Figure 42).

Checking the Alignment

Extend the leg to assess the alignment. Assemble the extramedullary rods and the modular handle and attach it to the distal cut guide (Figures 42–44). The alignment guide follows the mechanical axis of the leg, and should be aligned with the center of the femoral head, about two finger widths medial to the anterior superior iliac spine.

ⓘ **Note:** If the alignment guide shows a deviation from the middle of the upper ankle joint, the position of the femoral resection cut block must be corrected. A correction of 1° or 2° is made possible by using the 2° femoral correction block. For a larger deviation, the resection cut block must be re-positioned (Figures 35a, 35b, 35c).

ⓘ **Technique Tip:** The angle scale on the medial side of the instrument should read 0° on this step (Figure 39).





Figure 43



Figure 44

Check alignment by inserting alignment rods into the handle and/or the alignment rod slots in the tensor (Figures 42–44).



Figure 45



Figure 46



Figure 47

Attach saw guide to distal femoral cut block (Figure 45).

Resect the distal femur (Figures 46, 47).



Figure 48

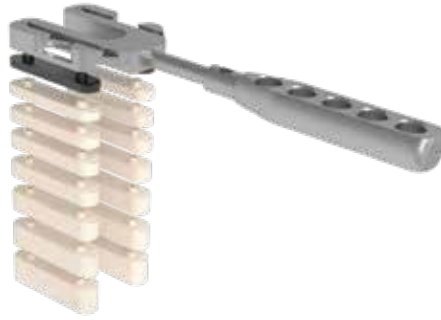

Figure 49



Figure 50

Check the flexion gap, using the FuZion Tensor or Tibial and Femoral distance plates (Figures 48–50).

⊖ **Note:** The spacers come in 1 mm thicknesses from 10 mm–14 mm, followed by 16 mm, 18 mm and 20 mm thickness (Figure 49).

If the flexion and extension are acceptable, this completes the anterior, posterior and distal resections.

⊖ **Technique Tip:** Check the gap with tibial and femoral plates to confirm parallel resections and proper ligament tension. However, there will be a slight extension deficit corresponding to the different angle of the distal femur cut in relation to the tibia cut (slope). The resulting full extension can then be checked with the trial implants.

Options to Correct AP Block Rotation & Positioning



Figure 51



Figure 52



Figure 53



Figure 54



Figure 55

Prior to making the anterior or posterior cuts, it may be necessary to adjust femoral rotation and or A/P position. Secondary shift blocks are available to make these adjustments. See examples in Figures 51–66.

ⓘ Technique Tip: The correction of the AP block rotation and positioning should be executed before the AP femoral resection (Figure 24). Alternatively, it can be corrected after checking the alignment (Figure 50).



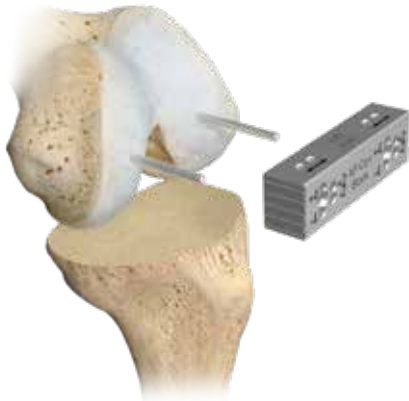

Figure 56



Figure 57



Figure 58



Figure 59



Figure 60



Figure 61

110040872





Figure 62



Figure 63



Figure 64



Figure 65



Figure 66



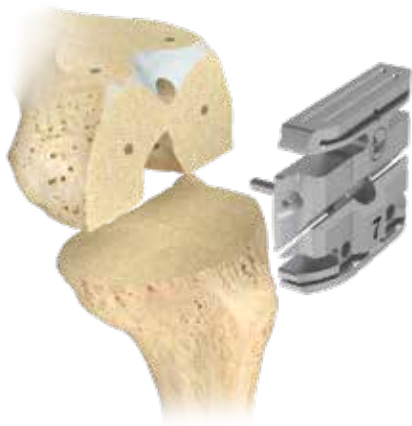

Figure 67



Figure 68

Chamfer Cuts

Following any adjustments and final flexion and extension gap checks, attach appropriate cut block (a-ref only) and complete the chamfer cuts (Figures 67–71).



Figure 69

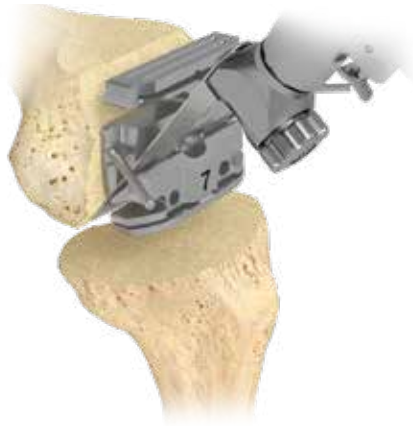

Figure 70



Figure 71

Use a saw blade perform complete posterior chamfer and anterior chamfer resections through the cut slots (Figures 69–71).

Finish using the Persona The Personalized Knee Surgical Technique, literature number 97-5026-001-00.

Notes

Lined writing area consisting of 26 horizontal lines.

All content herein is protected by copyright, trademarks and other intellectual property rights, as applicable, owned by or licensed to Zimmer Biomet or its affiliates unless otherwise indicated, and must not be redistributed, duplicated or disclosed, in whole or in part, without the express written consent of Zimmer Biomet.

This material is intended for health care professionals. Distribution to any other recipient is prohibited.

For indications, contraindications, warnings, precautions, potential adverse effects and patient counselling information, see the package insert or contact your local representative; visit www.zimmerbiomet.com for additional product information.

Not for distribution in France. Check for country product clearances and reference product specific instructions for use.

Zimmer Biomet does not practice medicine. This technique was developed in conjunction with health care professionals. This document is intended for surgeons and is not intended for laypersons. Animations and virtual reality are provided as a visual guide based on surgical techniques; a written copy of the surgical technique is available at www.zimmerbiomet.com or from your local representative. Each surgeon should exercise his or her own independent judgment in the diagnosis and treatment of an individual patient, and this information does not purport to replace the comprehensive training surgeons have received. As with all surgical procedures, the technique used in each case will depend on the surgeon's medical judgment as the best treatment for each patient. Results will vary based on health, weight, activity and other variables. Not all patients are candidates for this product and/or procedure. Caution: Federal (USA) law restricts this device to sale by or on the order of a surgeon. Rx only.

©2021, 2022 Zimmer Biomet



2750.2-GLBL-en-Issue Date-2022-01-27

 Biomet GSCC BV
Hazeldonk 6530
4836 LD Breda
The Netherlands

 **Legal Manufacturer**
Zimmer, Inc.
1800 West Center Street
Warsaw, Indiana 46580
USA
www.zimmerbiomet.com

 **Legal Manufacturer**
Zimmer GmbH
Sulzerallee 8
8404 Winterthur, Switzerland
Telephone +41/ (0) 58 854 80 00
Fax +41/ (0) 52 244 86 70
www.zimmerbiomet.com

 **Legal Manufacturer**
Zimmer Switzerland Manufacturing (ZSM) GmbH
Sulzerallee 8
8404 Winterthur, Switzerland
Telephone +41/ (0) 58 854 80 00
Fax +41/ (0) 52 244 86 70
www.zimmerbiomet.com

 2797

CE mark on a surgical technique is not valid unless there is a CE mark on the product label.