

Arcos[®] Modular Femoral Revision System

Broach and Calcar Proximal Bodies
Surgical Technique

Table of Contents

Pre-operative Planning	2
Patient Positioning and Surgical Approach	2
Removal of a Cemented Component	3
Removal of a Cementless Stem	3
Calcar/Broach Proximal Bodies & PPS® Distal Stems Sterile Field Technique	4
Preparation of the Diaphysis	4
Preparation of the Metaphysis	4
Broaching the Metaphysis	5
Calcar Resection	6
Trial Reduction	7
Implant Assembly	8
Implant Insertion	8
Inserting the Locking Screw	9
Final Reduction	9
Calcar/Broach Proximal Bodies & STS Distal Stems Sterile Field Technique	10
Preparation of the Diaphysis	10
Trialing the Distal Stem	10
Preparation of the Metaphysis	11
Broaching the Metaphysis	12
Calcar Resection	13
Trial Reduction	14
Implant Assembly	15
Implant Insertion	16
Inserting the Locking Screw	16
Final Reduction	17
Trochanteric Reattachment Technique	18
Attaching the Trochanteric Bolt Guide	18
Preparing For Auxiliary Implant Attachment	19
Final Attachment of the Auxiliary Implant	21
In-Femur Assembly	22
Implant Assembly	22
Inserter Disassembly	25
Inserting the Locking Screw	26
Final Reduction	27
Taper Compression Assembly	28
Proximal Body Insertion	28
Inserter Disassembly	30
Inserting the Locking Screw	31
Disengaging the Taper Junction	32
Disengaging the Proximal Body from the Distal Stem Implant	32

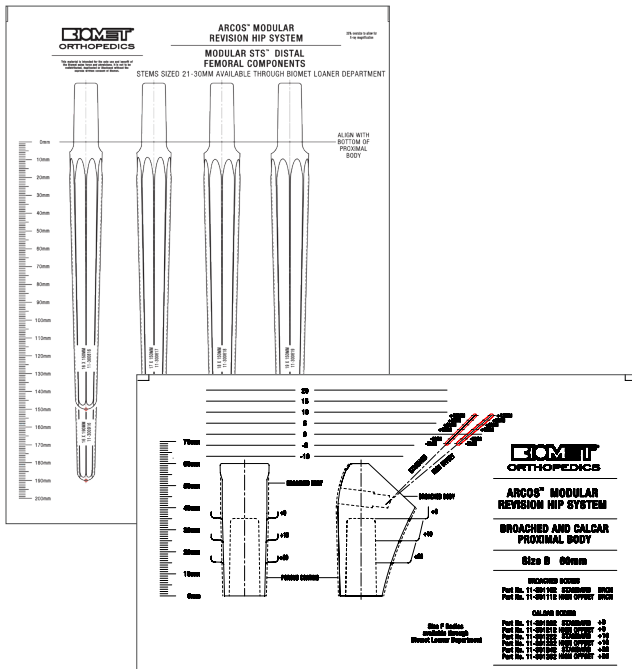

Figure 1

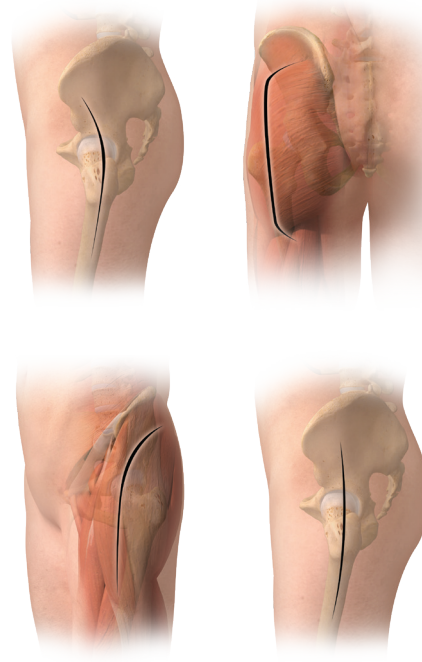

Figure 2

Pre-operative Planning

When planning a hip revision utilizing the Arcos Modular Femoral Revision System, carefully review the indications and contraindications for use referenced within the package insert.

The Arcos Modular Femoral Revision System is not designed for use in a fully unsupported proximal femur. Bone stock of adequate quality must be present and appraised at the time of surgery. The use of medial and/or lateral strut grafts may be necessary to support the taper junction in cases of severe proximal deficiency.

Utilizing A/P and M/L X-rays and implant templates will assist in determining the correct implant size, offset and position for a stable reconstruction (Figure 1). Final determination frequently cannot be made until the actual time of surgery. However, with appropriate planning, a consistent operative plan with alternatives can be formulated.

Patient Positioning and Surgical Approach

Patient position should be determined by the surgeon's preferred approach. The goal of the surgical approach is to establish adequate visualization of the anatomy (Figure 2).



Figure 3



Figure 4



Figure 5

Removal of a Cemented Component

Once the stem has been removed from the cement mantle by utilizing universal extraction instruments or manufacturer specific instruments, ensure all cement is removed prior to preparation of the femur for the Arcos femoral components (Figure 3). This can be achieved using the Ultra-Drive[®] cement removal system or cement removal tools. An osteotomy of the femur may be necessary to facilitate removal of the cement.

Removal of a Cementless Stem

Removal of a cementless stem may be difficult due to the biologic fixation that may exist between the implant and bone. When removing a proximally porous coated stem, it may be necessary to perform an osteotomy of the femur just below the level of the porous coating to assist in stem removal (Figure 4).

Note: An extended trochanteric osteotomy may be necessary if removing an extensively coated stem.

Sectioning the stem and utilizing trephine reamers can assist in the removal of the porous coated distal segment of a cementless stem (Figure 5).

Calcar/Broach Proximal Bodies & PPS Distal Stems Sterile Field Technique



Figure 6

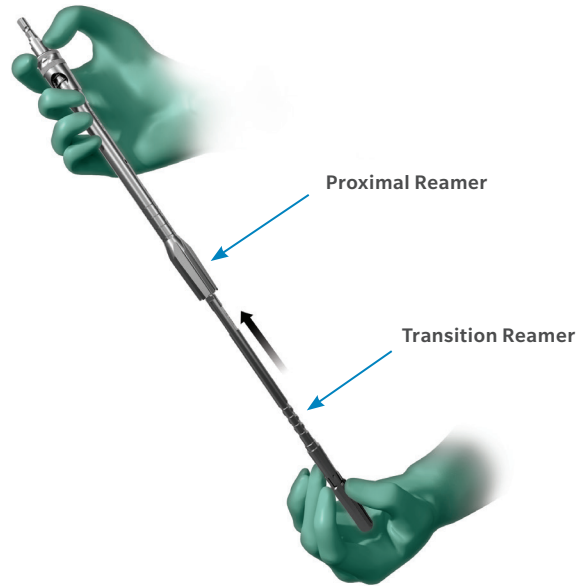

Figure 7

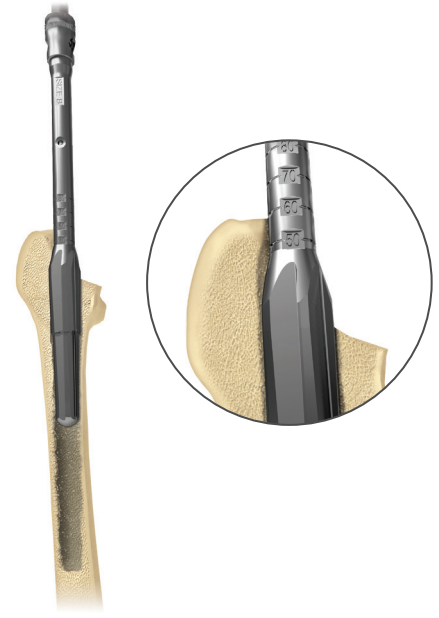

Figure 8

Preparation of the Diaphysis

To prepare the femur for a PPS coated distal stem, select flexible or thin shaft reamers and sequentially ream the femur two cortical diameters or 2–3 cm below the distal defect, increasing size until cortical “chatter” is achieved (Figure 6).

ⓘ **Note:** When utilizing flexible reamers, ream the canal in 0.5 mm increments until cortical “chatter” is achieved. The final reamer diameter should be line-to-line or 0.5 mm larger than the diameter of the desired implant, depending on bone quality.

ⓘ **Note:** Reaming over a guide is recommended. The Arcos distal reamers are designed to prepare the femur for a bowed distal stem and are cannulated to accommodate a guide wire.

Preparation of the Metaphysis

To prepare the proximal femur for the tapered region of the PPS distal stem and proximal body, assemble the transition reamer that is the same size as the desired distal stem into the proximal reamer and press down on the collar at the top of the proximal reamer to securely lock the two instruments together (Figure 7). Ream the proximal femur with the modular (transition/proximal) reamer, sequentially increasing the size of the proximal reamer, until the desired size (A–F) and the 60 mm proximal body height is achieved. The 60 mm etch mark of the proximal reamer should align with the tip of the greater trochanter (Figure 8).



Figure 9



Figure 10



Figure 11

Broaching the Metaphysis

Once the desired size and 60 mm proximal body height has been achieved utilizing the modular reamer, loosely assemble the proximal broach and the distal stem trial together using the 3.5 mm hex driver (Figure 9).

ⓘ **Note:** Assemble the proximal broach and distal stem trial loose to allow the distal stem to find the appropriate position in the femur.

Broach the proximal femur sequentially, until the final broach size matches the last proximal reamer used (Figure 10). Verify that the broach is advanced into the femur, oriented to the desired anteversion, and the 60 mm etch mark on the broach handle is aligned with the tip of the greater trochanter.

Once the desired broach size is obtained, remove the broach handle and tighten the broach's captured screw with the 3.5 mm hex driver to lock the broach into place (Figure 11).

ⓘ **Note:** Locking the broach and stem trial together will aid in matching the orientation of the trial to the final implant.

Calcar/Broach Proximal Bodies & PPS Distal Stems Sterile Field Technique



Figure 12

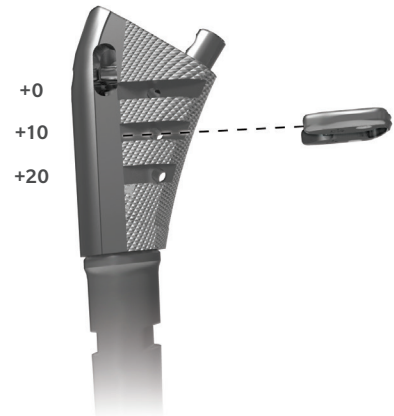

Figure 13

Calcar Resection

If utilizing the calcar proximal body implant, determine the level of deficiency in the proximal femur, align the resection guide to the broach and mark the desired resection with a saw (Figure 12). Remove the broach and stem trial with the broach handle and complete the calcar resection.

Insert either the large or small platform trial into the slot corresponding with the calcar resection level (Figure 13).

Note: The large platform should be utilized for a +0 resection level and the small platform should be utilized for the +10 or +20 resection levels.

Reattach the broach handle to the assembled trial and insert the trial into the femur to verify it seats to the desired level.



Figure 14

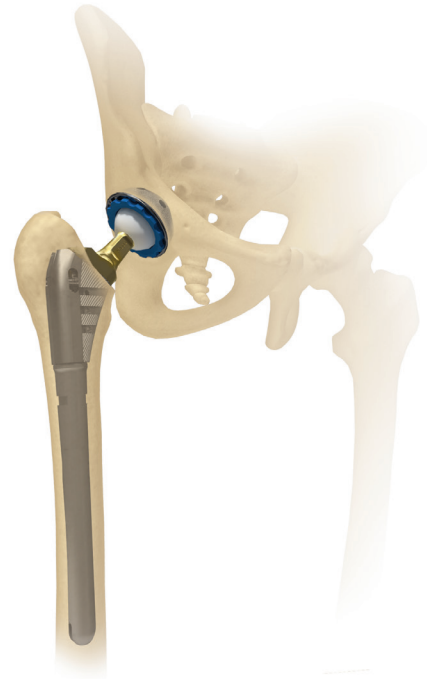

Figure 15

Trial Reduction

Utilizing the modular neck and head trials, perform a trial reduction of the hip and determine if the selected offset, leg length and joint stability are appropriate (Figures 14 and 15). When performing the trial range of motion, ensure the absence of impingement of the neck on the rim of the acetabular component or acetabular liner.

Note: The gold modular trials indicate standard offset and the black trials indicate high offset.

Once the desired offset, leg length and joint stability have been achieved, remove the modular neck and head trials. Reattach the broach handle to the assembled trial and remove the trial from the femur. Detach the broach handle from the assembled trial.

Calcar/Broach Proximal Bodies & PPS Distal Stems Sterile Field Technique



Figure 16



Figure 17



Figure 18

Implant Assembly

With the trial still assembled in the sterile field, assemble the distal stem and proximal body implants to match the orientation of the assembled trial (Figure 16).

ⓘ **Note:** If utilizing a slotted stem, a straight osteotome can be used in the slot of the trial and implant to properly orient the distal stem in relation to the proximal body.

When the desired orientation of the implants has been achieved, thread the green proximal body inserter to the assembled implant and impact the taper junction with at least three blows of the mallet on the back table (Figure 17).

Implant Insertion

With the proximal inserter still assembled to the implant, ensure the anti-rotation tabs are properly locked and insert the implant into the femur until the desired depth is achieved (Figure 18).

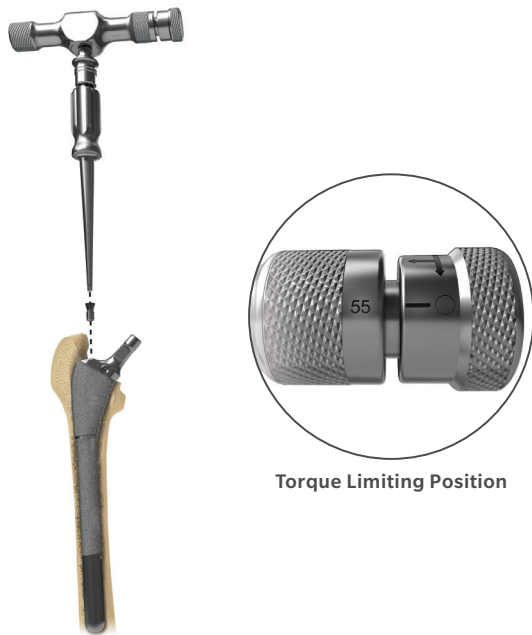

Figure 19

Inserting the Locking Screw

To lock the distal and proximal body implants, thread the locking screw into the top of the proximal body using the 3.5 mm hex driver and the T-handle in torque limiting position until a “click” is felt and heard (Figure 19).

Note: The screw can be used to lock the proximal body and distal stem together before the implants are inserted into the femur. If this is done, check the security of the screw once the implant has been fully seated.

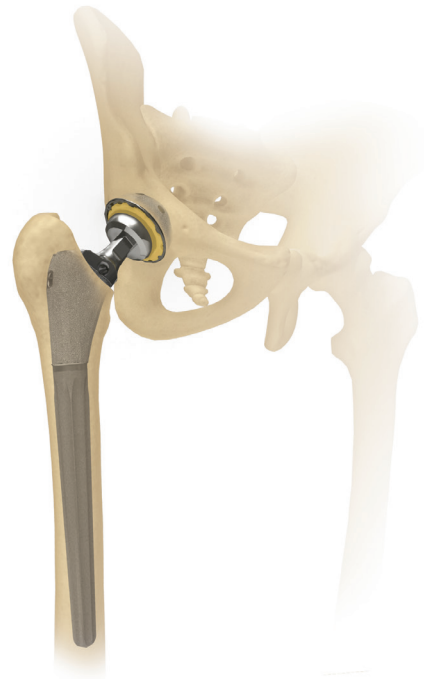

Figure 20

Final Reduction

If desired, another trial reduction can be accomplished prior to selecting final head size and impacting the modular head onto the stem (Figure 20). Provisional heads in seven neck lengths allow an additional trial reduction using the actual implant to ensure proper leg length and stability. After fully seating the femoral component, impact the appropriate modular head onto the clean, dry taper.

Calcar/Broach Proximal Bodies & STS Distal Stems Sterile Field Technique

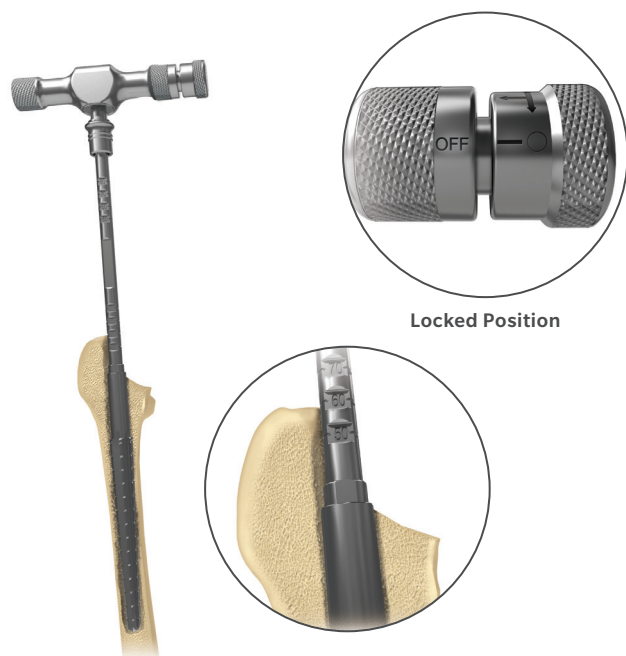

Figure 21



Figure 22

Preparation of the Diaphysis

To prepare the femur for an STS distal stem, select the STS reamers (silver reamers for 150 mm stem length and gold reamers for a 190 mm stem length). Assemble the STS reamer to the T-handle and turn the handle from torque limiting to the locked position.

Ream the femur in 1 mm increments by hand until the reamer advances to the 60 mm mark, referencing the tip of the greater trochanter (Figure 21).

Note: The final depth of the implant may vary from the depth of the reamer. How aggressively the femur is prepared and the quality of the bone may impact the depth that the final implant will seat. If the final implant sits proud of the desired ream depth, note the difference between these and utilize the last reamer used to ream deeper into the femur. Reaming the femur by hand may help avoid any discrepancy between the reamed depth and the final depth of the implant.

Trialing the Distal Stem

When distal femoral reaming is complete, select the stem trial that is the same diameter as the final reamer and the necessary length for stem stability. Thread the black distal trial inserter into the stem trial and insert the stem trial into the femur, matching the etched depth mark on the inserter to the depth achieved from the last STS reamer used (Figure 22).

Note: The stem trial and reamer are the same size. Both are 1 mm smaller than the femoral implant.

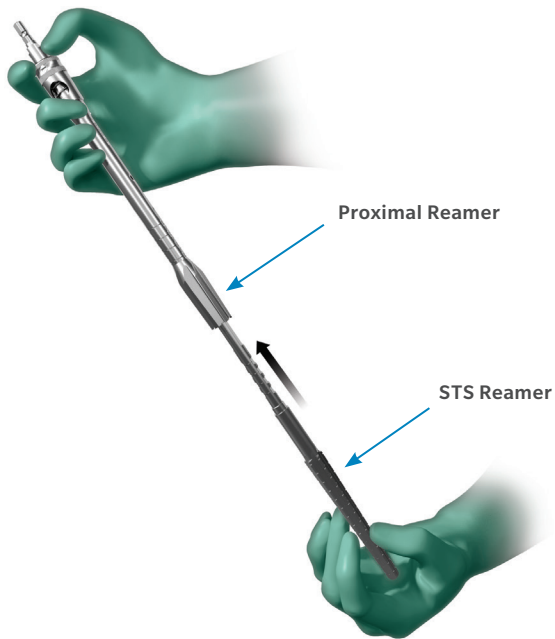

Figure 23

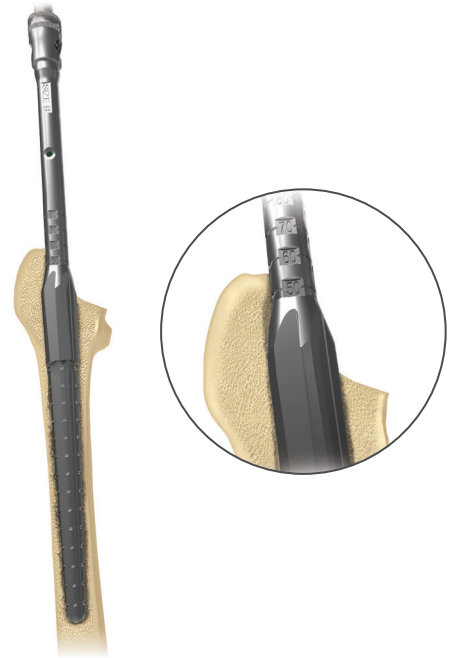

Figure 24

Preparation of the Metaphysis

To prepare the proximal femur, assemble the final STS reamer into the proximal reamer and press down on the collar at the top of the proximal reamer to securely lock the two instruments together (Figure 23). Ream the proximal femur, sequentially increasing the size of the proximal reamer, until the desired size (A–F) and the 60 mm proximal body height is achieved (Figure 24).

Calcar/Broach Proximal Bodies & STS Distal Stems

Sterile Field Technique



Figure 25



Figure 26

Broaching the Metaphysis

Once the desired size and 60 mm proximal body height has been achieved utilizing the STS/proximal reamers, assemble the proximal broach body and the distal stem trial together using the 3.5 mm hex driver (Figure 25).

Note: To keep the broach aligned with the femur, utilize the distal stem trial previously used.

Broach the proximal femur sequentially, until the final broach size matches the last proximal reamer used (Figure 26). Verify that the broach body is advanced into the femur, oriented to the desired anteversion and the 60 mm etch mark on the broach handle is aligned with the tip of the greater trochanter. Once the broach has been seated to the desired level, remove the broach handle from the assembled trial.



Figure 27

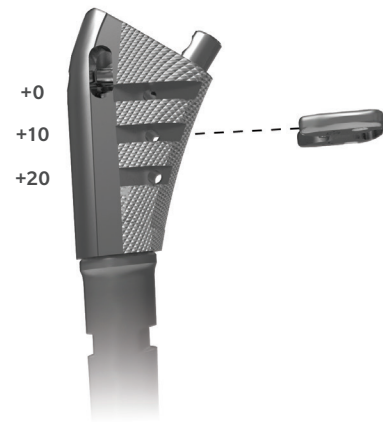

Figure 28

Calcar Resection

If utilizing the calcar proximal body implant, determine the level of deficiency in the proximal femur, align the resection guide to the broach and mark the desired resection with a saw (Figure 27). Remove the broach and stem trial with the broach handle and complete the calcar resection.

Insert either the large or small platform trial into the slot corresponding with the calcar resection level (Figure 28).

Note: The large platform should be utilized for a +0 resection level and the small platform should be utilized for the +10 or +20 resection levels.

Reattach the broach handle to the assembled trial and insert the trial into the femur to verify that it seats to the desired level.

Calcar/Broach Proximal Bodies & STS Distal Stems Sterile Field Technique



Figure 29

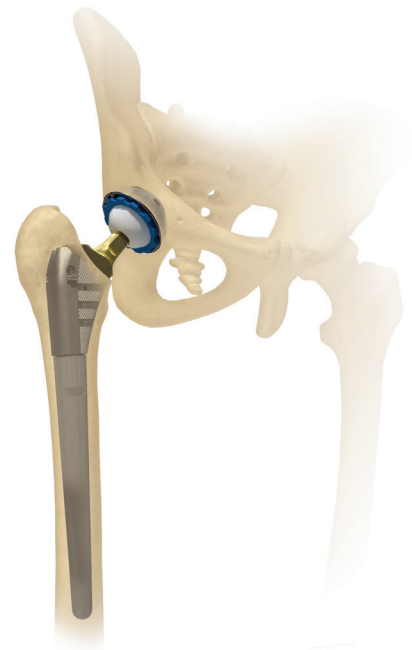

Figure 30

Trial Reduction

Utilizing the modular neck and head trials, perform a trial reduction of the hip and determine if the selected offset, leg length and joint stability are appropriate (Figures 29 and 30). When performing the trial range of motion, ensure the absence of impingement of the neck on the rim of the acetabular component or acetabular liner.

Note: The gold modular trials indicate standard offset and the black trials indicate high offset.

Once the desired offset, leg length and joint stability have been achieved, remove the modular neck and head trials. Reattach the broach handle to the assembled trial and remove the trial from the femur. Detach the broach handle from the assembled trial.



Figure 31



Figure 32

Implant Assembly

With the trial still assembled in the sterile field, assemble the distal stem and proximal body implants to match the orientation of the assembled trial (Figure 31).

ⓘ **Note:** If utilizing the 190 mm stem, ensure the bevel at the distal tip of the stem is oriented anteriorly.

When the desired orientation of the implants has been achieved, thread the green proximal body inserter to the assembled implant and impact the taper junction with at least three blows of the mallet on the back table (Figure 32).

Calcar/Broach Proximal Bodies & STS Distal Stems Sterile Field Technique



Figure 33



Figure 34

Implant Insertion

With the proximal inserter still assembled to the implant, ensure the anti-rotation tabs are properly locked and insert the final implant into the femur until the desired depth is achieved (Figure 33).

ⓘ **Note:** The final depth of the implant may vary from the depth of the reamer in this step. How aggressively the femur is prepared and the quality of the bone may impact the depth that the final implant will seat. If the final implant sits proud of the desired ream depth, note the difference between these and utilize the last reamer used to ream deeper into the femur. Reaming the femur by hand may help avoid any discrepancy between the reamed depth and the final depth of the implant.

Inserting the Locking Screw

To lock the distal and proximal body implants, thread the locking screw into the top of the proximal body using the 3.5 mm hex driver and the T-handle in torque limiting position until a “click” is felt and heard (Figure 34).

ⓘ **Note:** The screw can be used to lock the proximal body and distal stem together before the implants are inserted into the femur. If this is done, check the security of the screw once the implant has been fully seated.

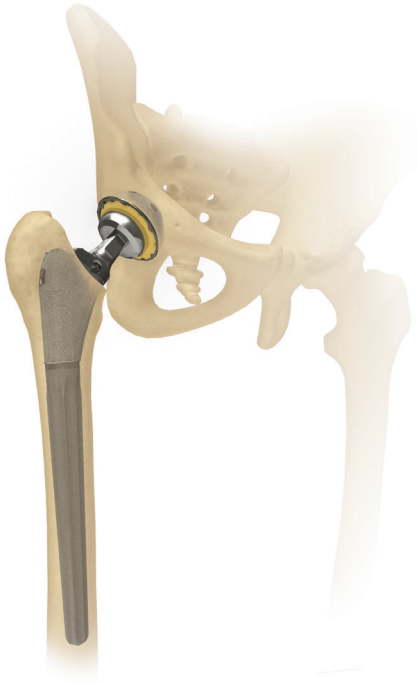

Figure 35

Final Reduction

If desired, another trial reduction can be accomplished prior to selecting final head size and impacting the modular head onto the stem (Figure 35). Provisional heads in seven neck lengths allow an additional trial reduction using the actual implant to ensure proper leg length and stability. After fully seating the femoral component, impact the appropriate modular head onto the clean, dry taper.

Trochanteric Reattachment Technique



Figure 36



Figure 37

Attaching the Trochanteric Bolt Guide

All proximal body designs accept a bolt and claw except the 50A Cone and 50A Calcar bodies.

Once the final implant has been reduced, the osteotomy can be repaired and stabilized by choosing one of the auxiliary options available in the Arcos System and attaching it directly to the implant.

Depending on the surgical approach and operative hip, select the appropriate trochanteric bolt guide instrument (Figure 36).

Use the 5.0 mm hex driver to thread the trochanteric bolt guide into the insertion hole on the proximal body, ensuring the anti-rotation tabs are locked to the proximal body implant. Place the trochanteric fragment between the implant and the trochanteric bolt guide (Figure 37).

If utilizing the trochanteric claw use the claw trials (large or small) to select the needed width.

Note: Guide may be easier to attach before hip is reduced.

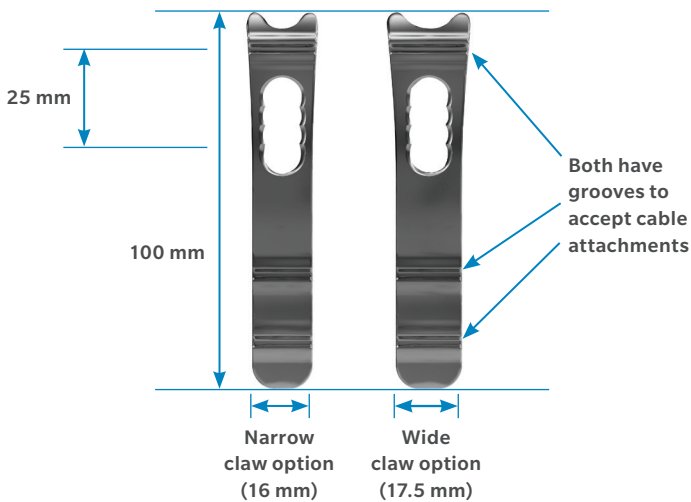

Figure 38

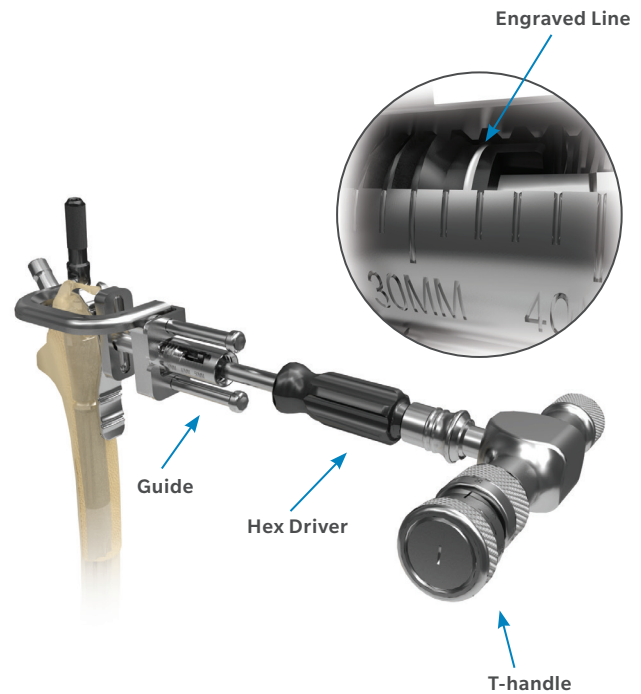

Figure 39

Preparing for Auxiliary Implant Attachment

ⓘ **Note:** Both the large and small claw are 100 mm in length, measured from the top to bottom. The button is 25 mm in diameter (Figure 38).

Once the trochanteric fixation option has been determined, compress the auxiliary implant to the bone fragment by threading the plunger tightly against the auxiliary implant using the 5.0 mm hex driver and T-handle in the torque limiting position (Figure 39).

ⓘ **Note:** If utilizing the claw auxiliary option, ensure that the head of the plunger is aligned with a hole in the claw to ensure that the bolt will pass through the claw into the implant.

Select the bolt length that corresponds with the depth marks on the outside of the trochanteric bolt guide as measured according to the position of the engraved line on the plunger. Choose the trochanteric bolt drill bit that matches the size of the proximal body implant (Size A–G) regardless of height or body style.

ⓘ **Example:** If a size B Cone body is used, select the size B trochanteric bolt drill bit. Selecting the correct size will prevent the drill from contacting the implant.

ⓘ **Note:** Bolts are available in 2 mm increments.

Trochanteric Reattachment Technique

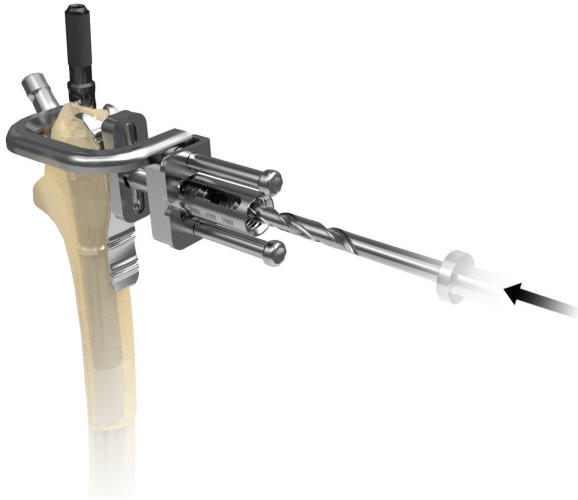

Figure 40

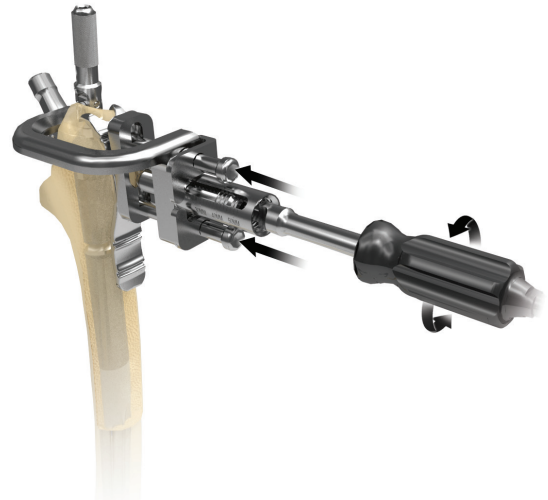

Figure 41

Preparing for Auxiliary Implant Attachment (cont.)

Advance the appropriate size drill bit through the plunger until the built-in stop bottoms out on the cylindrical surface of the outrigger (Figure 40).

ⓘ **Note:** It is not possible to drill through the bolt hole on the claw trial, preparation must be performed with the final implant in place.

Compress the arms of the trochanteric bolt guide tightly to the auxiliary implant and remove the measurement plunger with the 5.0 mm hex driver (Figure 41). Attach the 5.0 mm hex driver to the T-handle and set to torque limiting position.

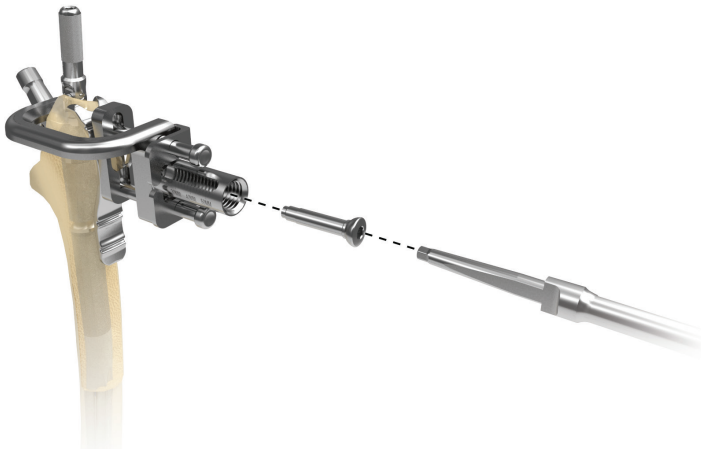

Figure 42



Figure 43



Figure 44

Final Attachment of the Auxiliary Implant

Thread the bolt through the trochanteric bolt guide and into the proximal body until a “click” is felt and heard (Figure 42).

ⓘ **Note:** It may be necessary to give the T-handle a few small taps with the mallet to ensure the bolt drops into the hole in the proximal body.

Once the bolt is secured to the implant, unthread the trochanteric bolt guide from the proximal body using the 5.0 mm hex driver (Figure 43).

ⓘ **Note:** If utilizing the claw auxiliary option, cables may be added in the grooves of the claw for additional stability (Figure 44).

ⓘ **Note:** If the trochanteric bolt guide is difficult to remove, unthread the trochanteric bolt by 1/2 a turn, remove the guide and retighten the bolt with the T-handle in torque limiting position.

In-Femur Assembly

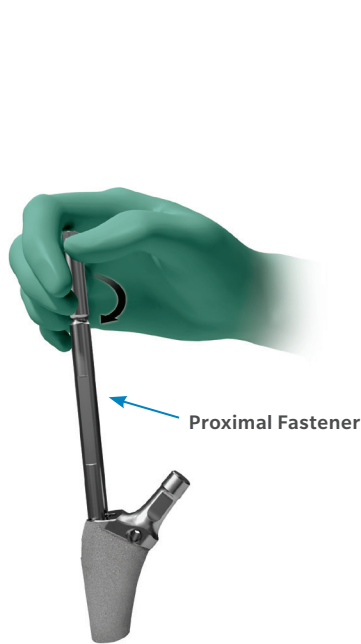

Figure 45



Figure 46

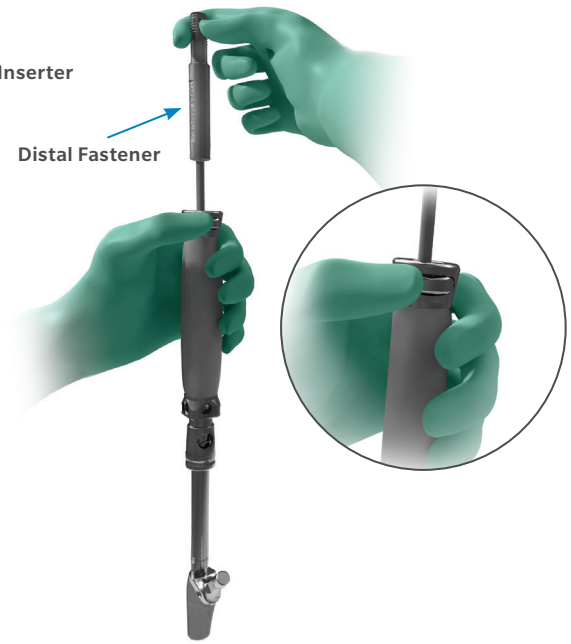

Figure 47

Implant Assembly

The in-femur assembly tool can be utilized with any proximal body and PPS coated distal stem construct and was designed to allow for a bowed distal stem to seat in the proper anatomic orientation, independent of the proximal body implant.

Once the diaphysis and metaphysis has been prepared and trialed, the in-femur assembly tool can be utilized for the final insertion of the implant and to securely lock the taper junction.

Thread the proximal fastener into the insertion hole on the proximal body implant (Figure 45). Slide the fastener into the gray proximal/distal inserter, pulling back on the inserter collar and locking the fastener into the inserter (Figure 46). Ensure that the anti-rotation tabs are locked to the implant.

Place the distal fastener that matches the selected proximal body height into the proximal/distal inserter handle. Depress the button at the top of the proximal/distal inserter handle and insert the assembly rod into the inserter (Figure 47).



Figure 48

Insert the 5.0 mm hex driver to the top of the proximal/distal inserter handle, hold the taper junction apart and thread the distal fastener into the distal stem (Figure 48).

ⓘ **Note:** Do not engage the taper junction when threading the distal fastener rod into the distal stem.

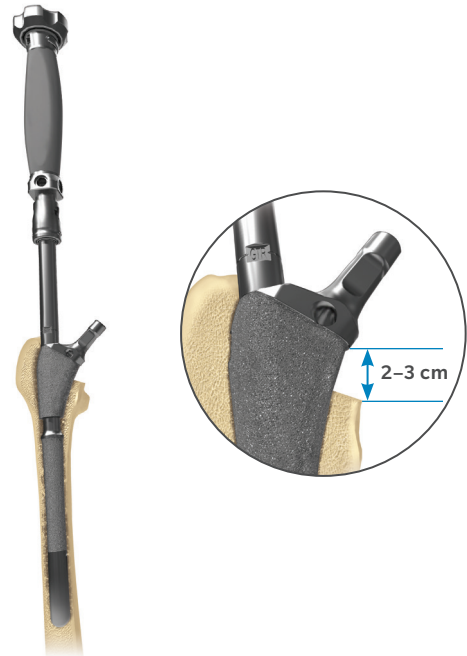

Figure 49

Attach the proximal/distal inserter handle strike plate, tightening until a “click” is felt and heard. Impact the proximal body until it is 2–3 cm proud of the desired depth (Figure 49).

ⓘ **Note:** When a “click” is heard, while tightening the strike plate, the proximal body and distal stem are separated and cannot be locked during insertion into the femur.

In-Femur Assembly

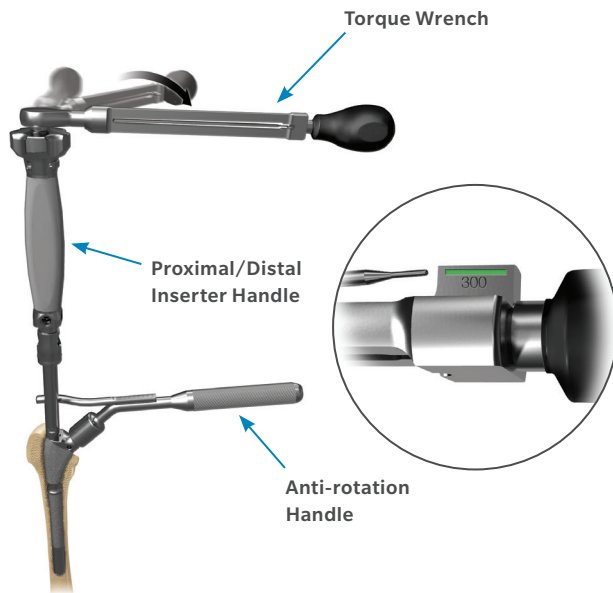

Figure 50



Figure 51

Implant Assembly (cont.)

To fully engage the taper junction, attach the torque wrench to the end of the proximal/distal inserter handle strike plate, place the anti-rotation handle over the implant neck and tighten until 300 in-lbs is indicated on the torque wrench shaft (Figure 50).

Disassemble the torque wrench and anti-rotation handle. Impact the stem to the desired depth (Figure 51).

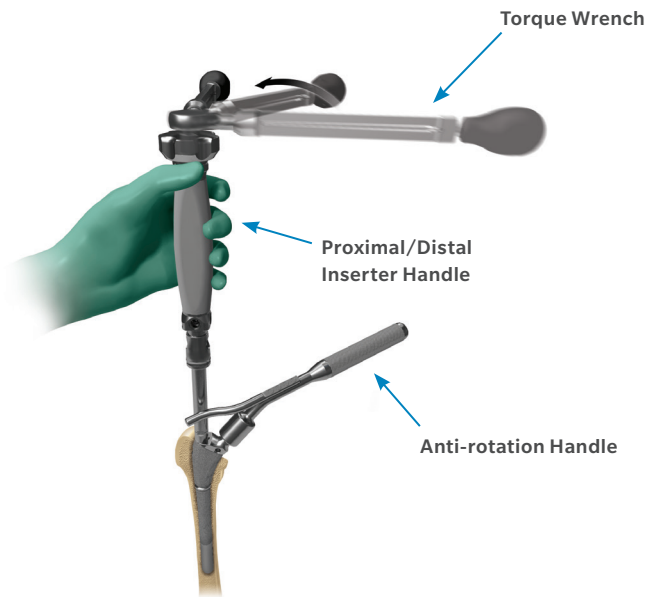

Figure 52



Figure 53

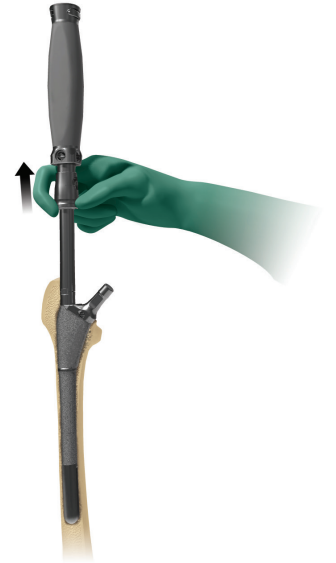

Figure 54

Inserter Disassembly

To loosen the strike plate, use the anti-rotation handle to hold the neck of the implant. Turn the torque wrench counter-clockwise and depress the button at the top of the proximal/distal inserter handle and unthread the strike plate (Figure 52).

Unthread the distal fastener from the distal stem implant using the 5.0 mm hex. Disengage the proximal/distal inserter by pulling back on the inserter collar (Figures 53 and 54).

In-Femur Assembly



Figure 55

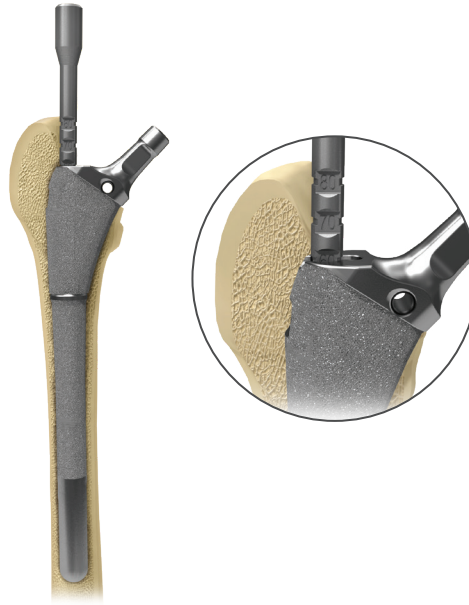

Figure 56



Torque Limiting Position

Figure 57

Inserter Disassembly (cont.)

To remove the proximal fastener, utilize the taper assembly driver and unthread the proximal fastener from the proximal body implant (Figure 55).

ⓘ **Note:** This inserter disassembly technique will NOT disassemble the implant.

ⓘ **Note:** To confirm that the proximal body is fully seated onto the taper junction an optional taper engagement tool is available. Insert the taper engagement tool into the top of the proximal body. Verify that the etch mark depth (50, 60, 70 or 80) on the engagement tool aligns with the lateral shoulder of the proximal body implant chosen (Figure 56). The taper engagement tool may only be used prior to inserting the locking screw.

Inserting the Locking Screw

To lock the distal and proximal body implants, thread the locking screw into the top of the proximal body using the 3.5 mm hex driver and T-handle in torque limiting position until a “click” is felt and heard (Figure 57).

ⓘ **Note:** If the screw does not thread into the distal stem the proximal body is not fully seated, the final implant assembly steps must be repeated.

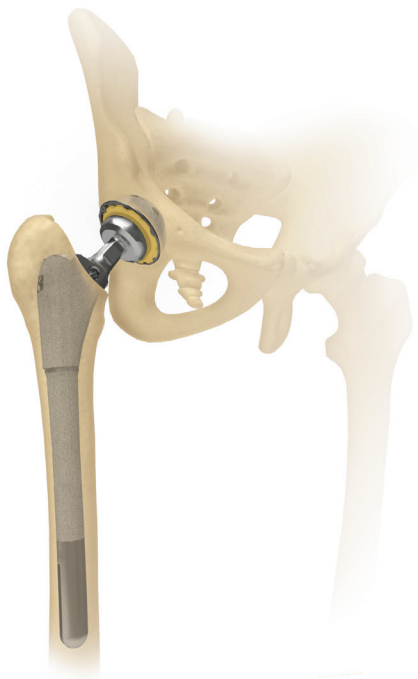

Figure 58

Final Reduction

If desired, another trial reduction can be accomplished prior to selecting final head size and impacting the modular head onto the stem (Figure 58). Provisional heads in seven neck lengths allow an additional trial reduction using the actual implant to ensure proper leg length and stability. After fully seating the femoral component, impact the appropriate modular head onto the clean, dry taper.

Taper Compression Assembly

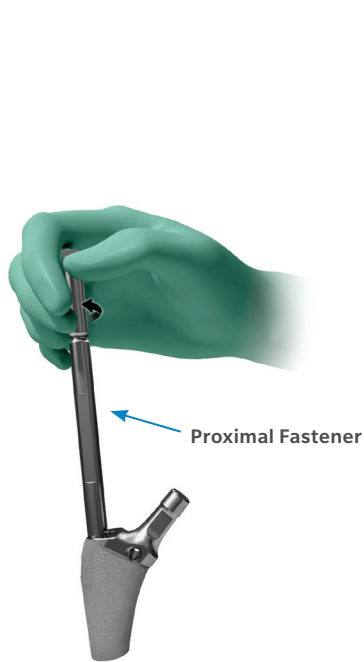

Figure 59



Figure 60

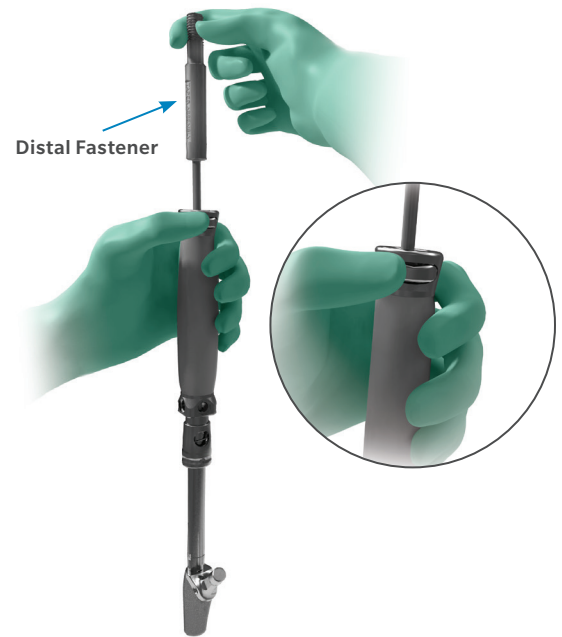

Figure 61

Proximal Body Insertion

Attaching the Proximal Body to the Distal Stem Implant

Once the desired offset has been chosen, ensure that the taper junction on the distal stem implant is clean and dry. Attach the proximal fastener to the proximal body implant by threading the proximal fastener into the insertion hole on the proximal body implant (Figure 59). Place the gray proximal/distal inserter handle over the proximal fastener by pulling back on the inserter collar and locking the fastener to the inserter (Figure 60). Ensure that the anti-rotation tabs are locked to the implant.

Place the distal fastener that matches the selected proximal body height into the proximal/distal inserter handle. Depress the button at the end of the proximal/distal inserter handle and insert the distal fastener into the inserter (Figure 61).



Figure 62



Figure 63

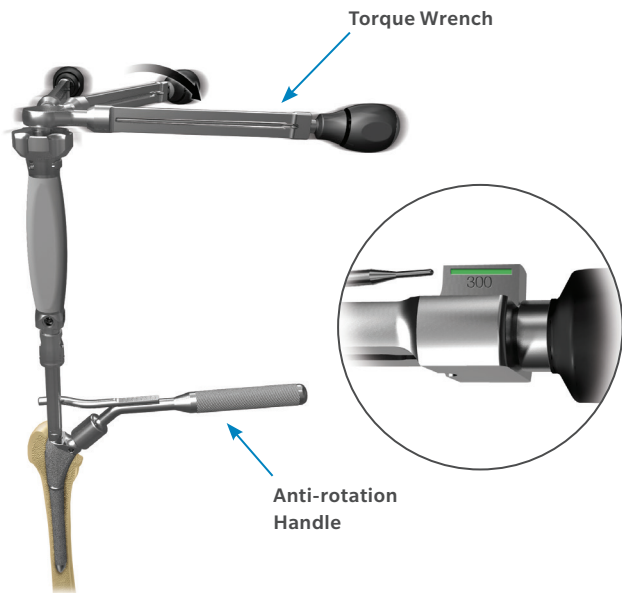

Figure 64

Insert the 5.0 mm hex driver into the top of the proximal/distal inserter handle and tightly thread the distal fastener into the distal stem (Figure 62). Attach the proximal/distal inserter handle strike plate, tightening until a “click” is felt and heard.

Set the desired version of the proximal body implant by turning the strike plate clockwise until it stops (Figure 63).

To fully engage the implant taper junction, attach the torque wrench to the end of the proximal/distal inserter handle strike plate. Place the anti-rotation handle on the implant neck and tighten until 300 in-lbs is indicated on the torque wrench shaft (Figure 64).

Taper Compression Assembly

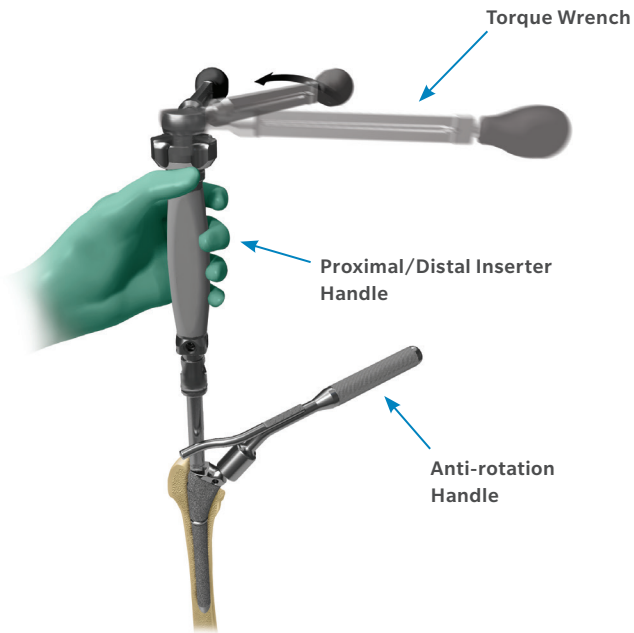

Figure 65



Figure 66

Inserter Disassembly

To remove the inserter from the fully seated implant, turn the torque wrench counter-clockwise while leveraging the anti-rotation handle. Depress the button at the top of the proximal/distal inserter handle and unthread the strike plate (Figure 65). Unthread the distal fastener from the distal stem implant using the 5.0 mm hex driver (Figure 66).

ⓘ **Note:** If the distal fastener is difficult to loosen with the 5.0 mm hex driver, attach the T-handle, set to the OFF position and turn counter-clockwise.

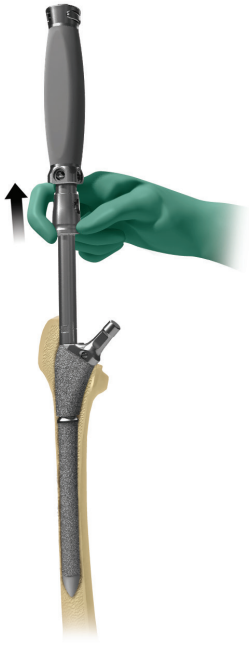

Figure 67



Figure 68

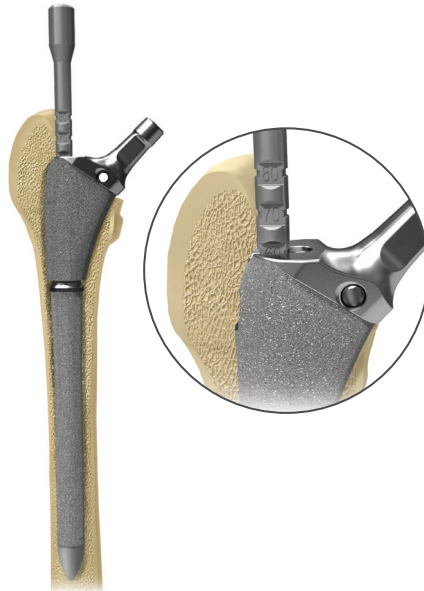

Figure 69



Figure 70

Disengage the proximal/distal inserter by pulling back on the inserter collar (Figure 67). To remove the proximal fastener, utilize the taper assembly driver and unthread the proximal fastener from the proximal body implant (Figure 68).

- ⓘ **Note:** This inserter disassembly technique will NOT disassemble the implant.
- ⓘ **Note:** To confirm that the proximal body is fully seated onto the taper junction an optional taper engagement tool is available. Insert the taper engagement tool into the top of the proximal body. Verify that the etch mark depth (50, 60, 70 or 80) on the engagement tool aligns with the lateral shoulder of the proximal body implant chosen (Figure 69). The taper engagement tool may only be used prior to inserting the locking screw.

Inserting the Locking Screw

To lock the distal and proximal body implants, thread the locking screw into the top of the proximal body using the 3.5 mm hex driver and T-handle in torque limiting position until a “click” is felt and heard (Figure 70).

- ⓘ **Note:** If the screw does not thread into the distal stem the proximal body is not fully seated and the final implant assembly steps must be repeated.

Disengaging the Taper Junction



Figure 71



Figure 72

Disengaging the Proximal Body from the Distal Stem Implant

To disengage the proximal body implant from the distal stem, remove the locking screw with the 3.5 mm hex driver and thread the taper disassembly tool that matches the proximal body height to the proximal body implant (Figure 71). Attach the torque wrench to the taper disassembly tool and, with the anti-rotation handle attached to the neck of the proximal body, turn the torque wrench clockwise until the proximal body disengages the distal stem (Figure 72). When resistance is felt, continue to slowly turn the torque handle and, after each quarter turn of the handle, pull the underside of the taper disassembly tool until the proximal body disengages.

- Note:** When disengaging the taper junction within the femur the proximal body may feel tight within the bone although the taper junction is disengaged. This is due to the initial fixation of the PPS coating to the bone. Gently tap the underside of the taper disassembly tool with the mallet to extricate the proximal body from the bone. Do NOT continue tightening the torque wrench as this may damage the implant.

This document is intended for surgeons and is not intended for laypersons. Each surgeon should exercise his or her own independent judgment in the diagnosis and treatment of an individual patient, and this information does not purport to replace the comprehensive training surgeons have received. As with all surgical procedures the technique used in each case will depend on the surgeon's medical judgment as the best treatment for each patient. Results will vary based on health, weight, activity and other variables. Not all patients are candidates for this product and/or procedure.

All content herein is protected by copyright, trademarks and other intellectual property rights, as applicable, owned by or licensed to Zimmer Biomet or its affiliates unless otherwise indicated, and must not be redistributed, duplicated or disclosed, in whole or in part, without the express written consent of Zimmer Biomet.

This material is intended for health care professionals, Zimmer Biomet employees and the Zimmer Biomet sales force. Distribution to any other recipient is prohibited.

Zimmer Biomet does not practice medicine. The treating surgeon is responsible for determining the appropriate treatment, technique(s), and product(s) for each individual patient.

The Arcos System was designed and developed in conjunction with Hugh Apthorp, FRCS, John Barrington, M.D., Keith R. Berend, M.D., J. Rod Davey, M.D., Edward McPherson, M.D., Christopher Peters, M.D., and Ian Stockley, FRCS. Zimmer Biomet does not practice medicine.

Caution: Federal (USA) law restricts this device to sale by or on the order of a surgeon. Rx only.

For product information, including indications, contraindications, warnings, precautions, and potential adverse effects, see the package insert and www.zimmerbiomet.com.

Check country product clearances and reference product specific instructions for use.

Not for distribution in France.

© 2017, 2021 Zimmer Biomet



 **Legal Manufacturer**
Biomet Orthopedics
P.O. Box 587
56 E. Bell Drive
Warsaw, Indiana 46581-0587
USA

www.zimmerbiomet.com

 2797

CE mark on a surgical technique is not valid unless there is a CE mark on the product label.