

NexGen[®] Cruciate Retaining (CR) and Revision Instrumentation

Surgical Technique



ZIMMER BIOMET
Your progress. Our promise.™

Table of Contents

Introduction	4
Revision Arthroplasty	4
Multi-Reference 4-in-1 Instrumentation System	
MICRO-MILL Instrumentation System	
Tibial Preparation	4
Extramedullary/Intramedullary Tibial Resector	
MICRO-MILL Instrumentation System	
Patellar Preparation	4
Patella Reamer Technique	
Universal Saw Guide Technique	
Femoral Preparation for Primary Arthroplasty	5
Multi-Reference 4-in-1 Instrumentation	5
Step One: Establish Femoral Alignment	
Step Two: Cut the Distal Femur	
Step Three: Size Femur and Establish External Rotation	
Anterior Referencing Technique	
Posterior Referencing Technique	
Determine Proper External Rotation	
Step Four: Finish the Femur	
MICRO-MILL/5-in-1 Instrumentation.....	15
Step One: Size the Femur	
Step Two: Establish Femoral Alignment	
Step Three: Set A/P Position of the Femur	
Step Four: Secure Femoral Mounting Bases	
Optional 4-inch Intramedullary Alignment Guide Technique	
Step Five (Milling): Femoral Resection	
Step Six (Milling): Finish the Femur	
Step Five (5-in-1): Femoral Resection	
Step Six (5-in-1): Finish the Femur	
“Crossover” Technique.....	29
Introduction	
“Crossover” Technique	
Epicondylar Notch/Chamfer Guide	
5-in-1 Finishing/Notch Guide	
Notch/Chamfer Guide	
Tibial Preparation for Primary Arthroplasty	32
Spike Arm Extramedullary Technique	32
Step One: Assemble Alignment Guide	
Step Two: Position Alignment Guide	
Step Three: Set Resection Level	
Step Four: Resect the Proximal Tibia	

Cut Guide Extramedullary Technique	37
Step One: Assemble Alignment Guide	
Step Two: Position Alignment Guide	
Step Three: Set Resection Level	
Step Four: Resect the Proximal Tibia	
Cut Guide Intramedullary Technique	42
Step One: Position IM Alignment Guide	
Step Two: Set Resection Level	
Step Three: Resect the Proximal Tibia	
Spike Arm Intramedullary Technique	48
Step One: Insert IM Rod	
Step Two: Position Cut Guide	
Step Three: Set Resection Level	
Step Four: Resect the Proximal Tibia	
MICRO-MILL/5-in-1 Instrumentation.....	53
Step One: Align the Tibia	
Step Two (Milling): Resect the Tibia	
Step Two (5-in-1): Resect the Tibia	
Finish the Tibia	59
Position Based on Anatomic Landmarks	
Position Based on Trial Range of Motion	
Pegged Tibial Plate Preparation	
Stemmed Tibial Plate Preparation	
Patellar Preparation	64
Prepare the Patella	64
Resect the Patella	65
Patella Reamer Technique Total Surfacing Procedure	
Insetting Technique	
Universal Saw Guide Technique	
Finish the Patella	68
NexGen Primary Porous Patella with Trabecular Metal Material	
NexGen All-Polyethylene Patella	
Augmentation Patella	70
Component Size Selection and Bone Preparation	
Trial Reduction	
Securing the Augmentation Patella Base	
Cementing the All-Polyethylene Patella	
Trial Reduction and Implantation	72
Trial Reduction	72
Femoral Recutting/Downsizing	72
For MICRO-MILL/5-in-1 Instrumentation	
For Intramedullary, Epicondylar, or Multi-Reference	
4-in-1 Femoral Instrumentation	
Component Implantation	74
Bearing Insertion.....	74

Introduction

This surgical technique document combines the many instrumentation and technique options available to the surgeon when implanting the NexGen CR Total Knee Prostheses. The surgeon should choose the preferred instrumentation system preoperatively. Instruments/techniques for femoral, tibial, and patellar preparation can be chosen independently from the following:

Revision Arthroplasty

Multi-Reference® 4-in-1 Instrumentation System

This system follows the “distal cut first” philosophy, establishing a flat distal femoral cut on which to position subsequent instruments. It offers a choice of anterior or posterior referencing, and a choice of fixed 3°, 5°, 7° of external femoral rotation or defining femoral rotation by epicondylar referencing.

MICRO-MILL® Instrumentation System

This system provides a single, rigid reference point for all precision femoral cuts. It offers a choice of making the femoral cuts with a saw blade and a single cutting guide, or milling the femur with a cutter that is similar to a router bit and precision milling templates.

Tibial Preparation

Extramedullary/Intramedullary Tibial Resector

This system provides a choice of four techniques for tibial resection, each offering a number of options to accommodate various anatomical conditions and surgeon preferences. The cutting guide, which can be used for both extramedullary and intramedullary techniques, allows the depth of cut to be adjusted after the guide has been positioned.

MICRO-MILL Instrumentation System

This system offers a choice of making the tibial cut with a saw blade, or milling the tibia with a cutter that is similar to a router bit. Tibial milling templates are provided in a variety of sizes so that bone may be removed without harming the soft tissue, and a solid, well-defined posterior cruciate island may be created.

Patellar Preparation

Patellar Reamer Technique

This technique uses a reamer to resect the patella, and offers a choice of total surfacing or inseting techniques.

Universal Saw Guide Technique

This technique uses a universal saw guide and saw blade to resect the patella.

Femoral Preparation for Primary Arthroplasty

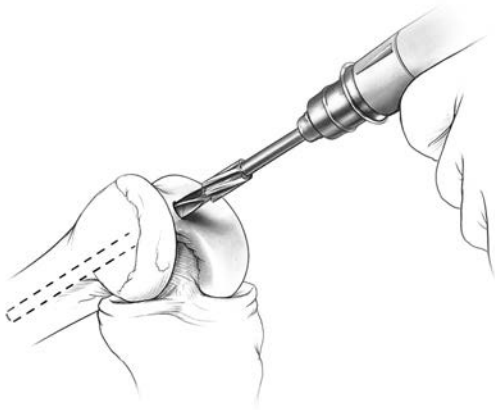

Figure 1

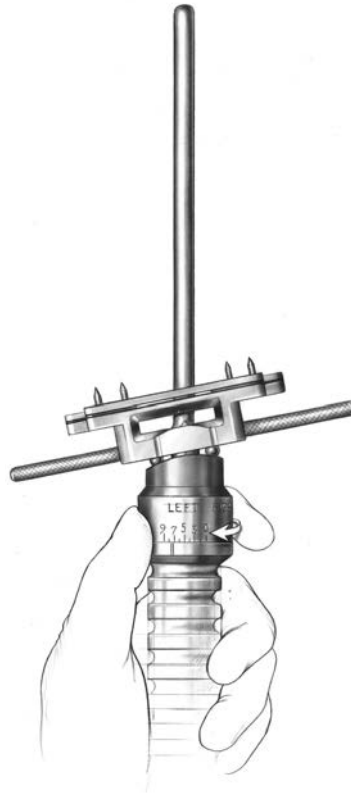

Figure 2



Figure 3

Multi-Reference 4-in-1 Instrumentation

Step One: Establish Femoral Alignment

Drill a hole in the center of the patellar sulcus of the distal femur (Figure 1), making sure that the hole is parallel to the shaft of the femur in both the anteroposterior and lateral projections. The hole should be approximately one-half to one centimeter anterior to the origin of the posterior cruciate ligament. Medial or lateral displacement of the hole may be needed according to preoperative templating of the A/P radiograph.

Use the 8 mm IM drill with step to enlarge the entrance hole on the femur to 12 mm in diameter. This will reduce intramedullary pressure during

placement of subsequent IM guides. Suction the canal to remove medullary contents.

Set the IM alignment guide to the proper valgus angle as determined by preoperative radiographs. Check to ensure that the proper “Right” or “Left” (Figure 2) indication is used and engage the lock mechanism (Figure 3).

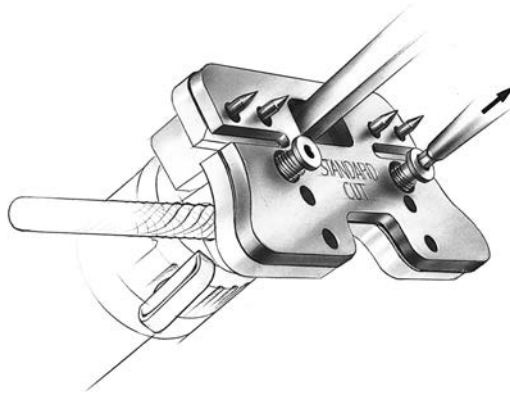

Insert the guide into the IM hole on the distal femur.

Figure 4

Step One: Establish Femoral Alignment (cont.)

The standard cut block must be attached to the IM alignment guide for a standard distal femoral resection. The plate should be tightened on the guide prior to use, but the screws should be loosened for sterilization. Remove the standard cut block if a large flexion contracture exists. This will allow for an additional 3 mm of distal femoral bone resection (Figure 4). The level of distal resection can also be adjusted with the Epi distal cut guide as shown in **STEP TWO**.

Note: Spacer blocks can be used to check flexion-extension gap spacing before recutting the distal femur.

Use the epicondylar axis as a guide in setting the

orientation of the IM alignment guide. Position the handles of the guide relative to the epicondyles. This does not set rotation of the femoral component, but keeps the distal cut oriented to the final component rotation.

Once the proper orientation is achieved, impact the IM guide until it seats on the most prominent condyle. After impacting, check to ensure that the valgus setting has not changed. Ensure that the guide is contacting at least one distal condyle. This will set the proper distal femoral resection.

Optional Technique

An extramedullary alignment arch and alignment rod can be used to confirm the alignment. If this is anticipated, identify the center of the femoral head before draping. If extramedullary alignment will be the only mode of alignment, use a palpable radiopaque marker in combination with an A/P X-ray to ensure proper location of the femoral head.

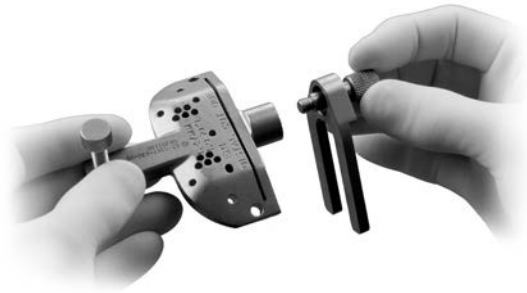

Figure 5



Figure 7



Figure 6

Distal femoral
cutting guide-pin
hole locations



Completely loosen the attachment screw
(Figure 8) in the distal placement guide.



Figure 8

Step Two: Cut the Distal Femur

While the IM alignment guide is being inserted by the surgeon, the scrub nurse should attach the distal femoral cutting guide to the appropriate distal placement guide. If a posterior referencing technique will be employed, consider using the 3° distal placement guide. This will place the distal resection guide, and therefore the distal cut in 3° of flexion to help prevent notching of the anterior cortex. If an anterior referencing technique will be employed, use the 0° distal placement guide.

Ensure that the attachment screw is tightened (Figure 5). Verify that the anterior thumb screw is backed out, away from the bone surface.

Insert the distal placement guide with the cutting guide into the im alignment guide until the cutting guide rests on the anterior femoral cortex.

To further stabilize the guide, turn the anterior

screw by hand until it contacts the anterior femoral cortex (Figure 6). Do not overtighten.

Optional Technique

The 3° distal placement guide can be used to place the distal resection guide in 3° of flexion to protect the anterior cortex from notching for anterior referencing as well.

Drill two holes using the 1/8 in. drill. Place headless holding pins through the two standard pin holes in the anterior surface of the distal femoral cutting guide marked "0" (Figure 7).

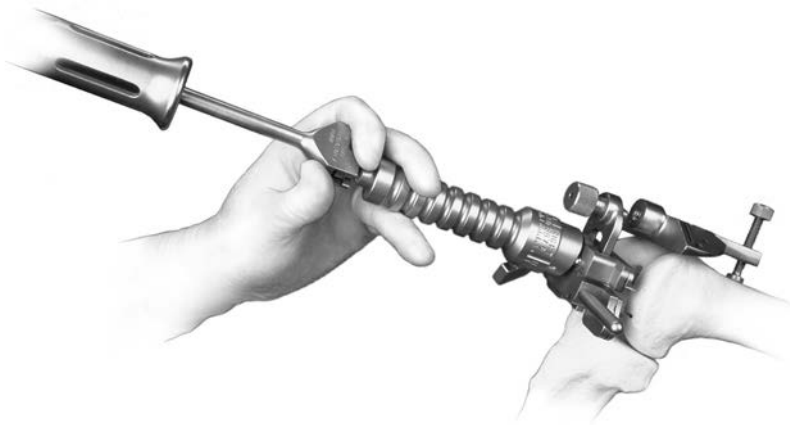

Figure 9

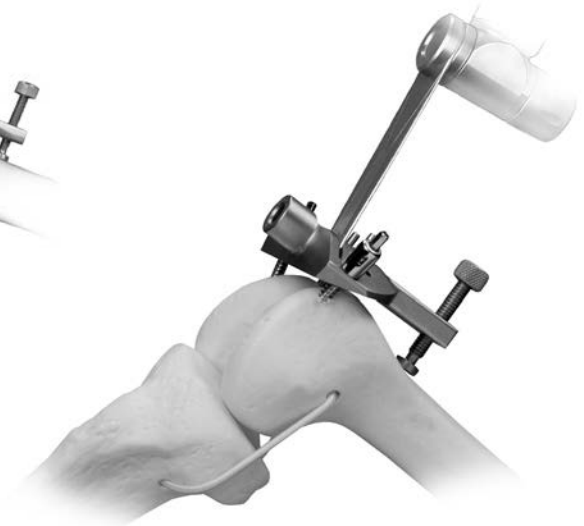

Figure 10

Step Two: Cut the Distal Femur (cont.)

Use the slaphammer extractor to remove the IM alignment guide and the distal placement guide (Figure 9).

To facilitate flexion/extension gap balancing, additional 2 mm adjustments may be made by using the sets of holes marked -4, -2, +2, and +4. The markings on the cutting guide indicate, in millimeters, the amount of bone resection each will yield relative to the standard distal resection set by the adjustable IM alignment guide and standard cut block. Once the distal femoral resection has been determined, use holding pins and/or silver spring pins to further stabilize the guide.

Cut the distal femur through the distal cutting slot in the cutting guide using a .050-inch/1.27 mm oscillating saw blade (Figure 10).

Check the flatness of the distal femoral cut with a flat surface. If necessary, modify the distal femoral surface so that it is completely flat. This is extremely important for the placement of subsequent guides and for proper fit of the implant.

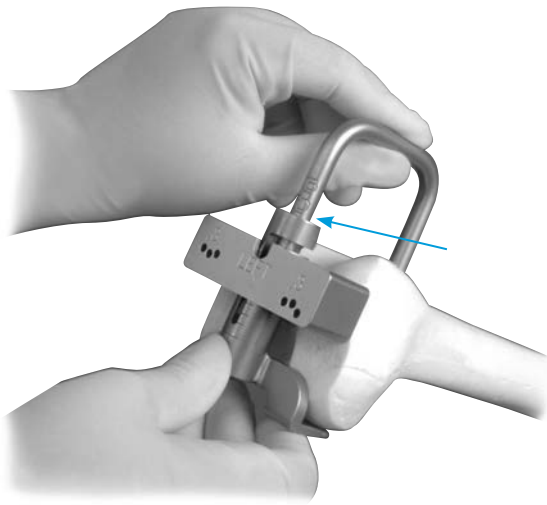

Anterior referencing

Figure 11

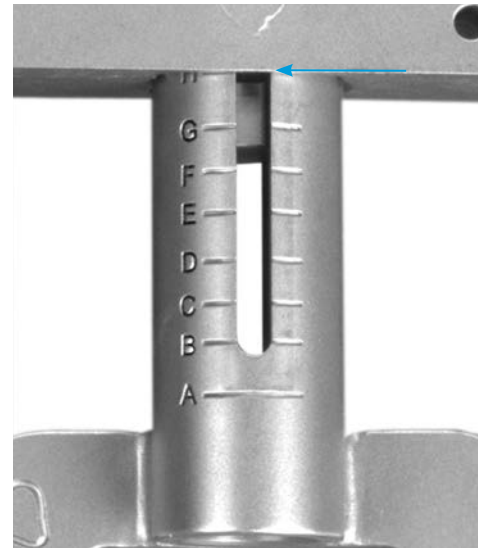

Posterior cylinder detail posterior referencing

Figure 12

Step Three: Size Femur and Establish External Rotation

Place the 4-in-1 femoral A/P sizing guide flat onto the smoothly cut distal femur, this is the only sizing guide that can be used with the 4-in-1 system. Check to ensure that the proper “Right” or “Left” designation is showing on the guide. Make sure that the body of the guide maintains contact with the resected distal femur. Compress the guide until the anterior boom contacts the anterior cortex of the femur, and both feet rest on the cartilage of the posterior condyles. Check to ensure that the boom is not seated on a high spot, or an unusually low spot on the anterior cortex. The position of the boom dictates the exit point of the anterior bone cut and the ultimate position of the femoral component.

There are eight sizes labeled “A” through “H.”

Anterior Referencing Technique

For an anterior referencing technique, read the femoral size directly from the size guide on the anterior boom (Figure 11). If the indicator is between two sizes, the smaller size is typically chosen. This prevents excessive ligament tightness in flexion.

Posterior Referencing Technique

For a posterior referencing technique, identify the femoral size range from the size guide on the posterior cylinder (Figure 12). If the indicator is between two sizes, the larger size is typically chosen. This prevents notching of the anterior cortex. Adjust the sizing guide placement by moving the anterior boom on the anterior cortex until the guide rests directly on the appropriate size mark on the posterior cylinder. Use the position of the anterior boom to visualize the exit point of the anterior bone cut, and the ultimate A/P position of the femoral component. This discrete placement will ensure that the amount of posterior bone resection will average 9 mm (the thickness of the posterior condyles of the standard NexGen Femoral Component, sizes C-H) (Figure 12).

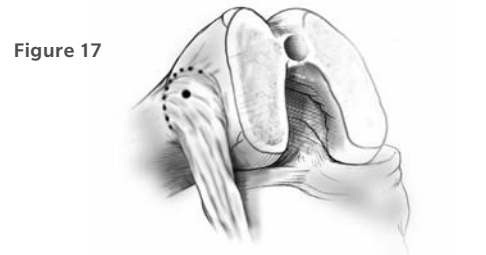
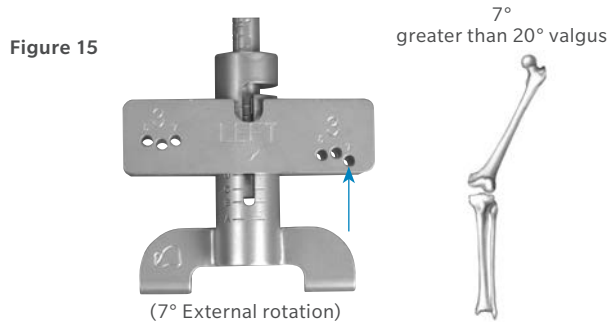
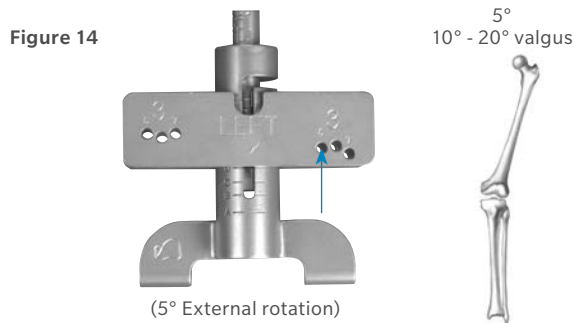
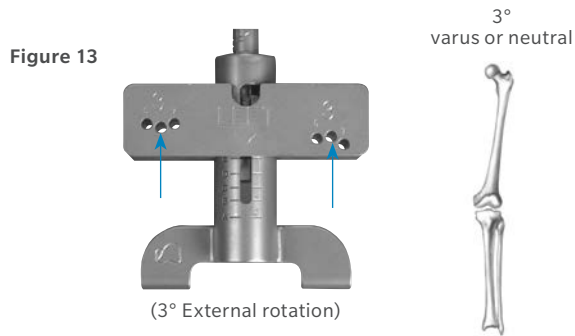

Determine Proper External Rotation

The 4-in-1 femoral A/P sizing guide offers three external rotation choices: 3°, 5°, and 7°.

For all varus knees, use the 3° rotation option (Figure 13). For knees with a valgus deformity of 10°-20°, use the 5° option (Figure 14). For knees with patellofemoral disease accompanied by bone loss and valgus deformity greater than 20°, use the 7° option (Figure 15).

Anterior Referencing

For an anterior referencing technique, place two headless holding pins into the appropriate external rotation holes in the body of the 4-in-1 femoral A/P sizing guide. Impact them flush with the guide (Figure 16). Remove the sizing guide, but leave the two headless pins. These pins will serve to establish A/P position and rotational alignment of the femoral finishing guide.

Optional Technique

Another method of setting external rotation is to identify the epicondylar axis. To identify the lateral epicondyle, it is necessary to dissect away the patellofemoral ligament. The lateral epicondyle is a discrete point at the center of the lateral collateral ligament attachment. The medial epicondyle can be found by removing the synovium from the medial collateral ligament attachment to the femur. The medial collateral ligament has a broad attachment to the medial epicondyle forming an approximate semicircle (Figure 17). Choose the center of the diameter. Mark these two points with methylene blue (Figure 18). Then, draw a line between the two epicondyles on the resected surface of the distal femur (Figure 19). This line represents the epicondylar axis.



Figure 19



Figure 21

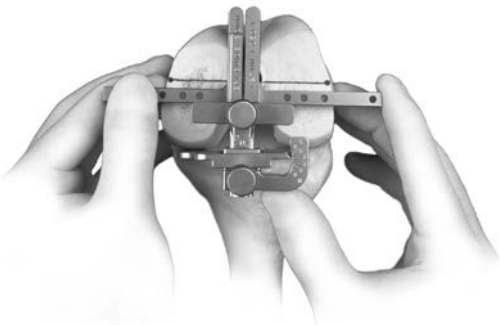

Figure 20

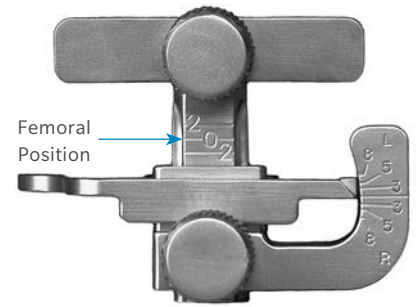

Figure 22

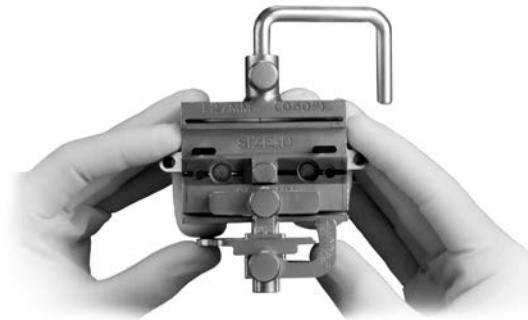

Figure 23

Determine Proper External Rotation (cont.)

Attach the posterior reference guide to the epicondylar guide. Place the epicondylar guide on the distal femur, bringing the feet of the rotation guide flush against the posterior condyles of the femur (Figure 20). Set the rotation of the epicondylar guide parallel to the epicondylar axis. Read the angle of external rotation indicated by the posterior reference/rotation guide. The epicondylar line is rotated externally $0-8^{\circ}$, ($4^{\circ} \pm 4^{\circ}$) relative to the posterior condyles. Determine the external rotation (3° , 5° , 7°) that most closely matches the indicated rotation.

Posterior Referencing

For the posterior referencing technique, select the correct size 4-in-1 femoral finishing guide as determined by the measurement from the A/P sizing guide. Assemble the posterior reference/rotation guide to the selected femoral guide (Figure 21).

Lock the femoral position indicator on the rotation guide to the zero position (Figure 22). This zero setting ensures that, when the feet are flush with the posterior condyles, the amount of posterior bone resection will average 9 mm. Swing the anterior boom on the finishing guide out of the way. Place the finishing guide on the distal femur, bringing the feet of the rotation guide flush against the posterior condyles of the femur (Figure 23).

Set the rotation of the finishing guide to parallel the epicondylar axis. Check the rotation of the guide by reading the angle indicated by the posterior reference/rotation guide. The epicondylar line is rotated externally $0^{\circ}-8^{\circ}$, ($4^{\circ} \pm 4^{\circ}$), relative to the posterior condyles. Pin the guide to the distal femoral.

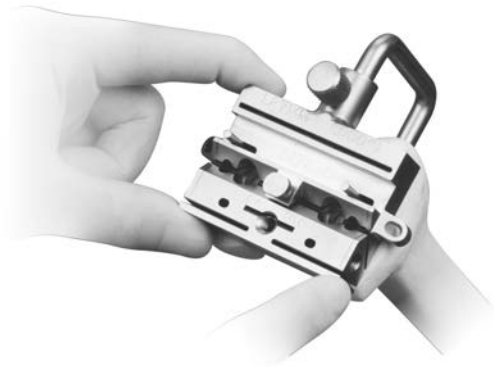

Figure 24

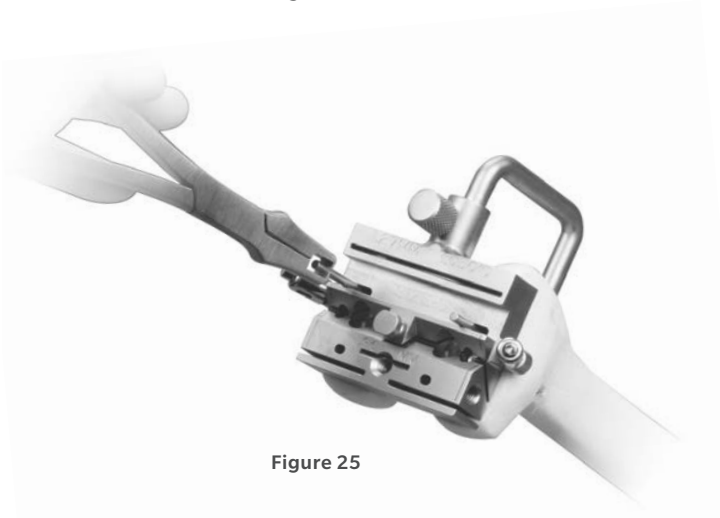
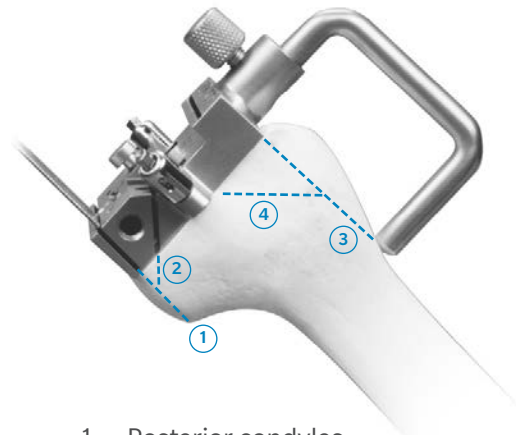

Figure 25



1. Posterior condyles
2. Posterior chamfer
3. Anterior flange
4. Anterior condyles
5. Base of trochlear recess
6. Drill peg holes

Figure 26

Step Four: Finish the Femur

Select the correct size 4-in-1 femoral finishing guide as determined by the measurement from the A/P sizing/rotation guide. Place the finishing guide onto the distal femur, over the headless pins. This determines the A/P position and rotation of the instrument. (The anterior boom on the finishing guide indicates the depth at which the anterior cut will exit the femur and may be used as a check.) The finishing guide may be positioned mediolaterally by sliding it on the headless pins (Figure 24).

The width of the finishing guide replicates the width of the distal NexGen CR Femoral Component. The etched lines on the posteromedial and posterolateral surface of the guide reference the width of the NexGen Legacy® Knee Posterior Stabilized (LPS) Femoral Component (Figure 25). For the posterior referencing technique, use the posterior reference/rotation guide to check that the posterior resection is appropriate, that is, reads on the “0” mark.

Pin the 4-in-1 femoral finishing guide to the distal femur with two short-head holding pins through the front. Use the universal handle to impact these pins. To further stabilize the guide, insert a silver spring pin through the tab on each side of the guide using the female hex driver and drill reamer. The pins are designed to automatically disengage the hex driver when fully seated on the guide. Remove the headless pins (Figure 25).

Use the .050-inch/1.27 mm oscillating saw blade to cut the femur. Perform the final femoral cuts in the following sequence to allow the guide to maintain optimal stability during bone resection (Figure 26).



Figure 27



Figure 28

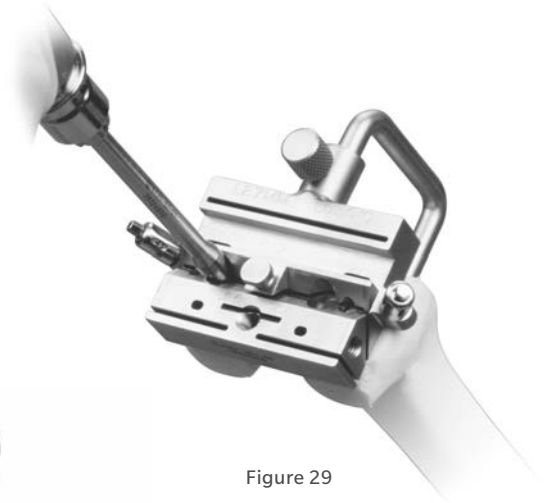

Figure 29

Step Four: Finish the Femur (cont.)

Use the center slot on the distal face of the guide to cut the base of the trochlear recess with a reciprocating saw (Figure 27). Ensure that the saw blade is in line with the femur throughout the cut, and do not angle or fan the blade medially or laterally.

Use the two slots on the anterior surface of the guide to make reference marks by scoring the femur with a reciprocating saw blade. This determines the sides of the trochlear recess (Figure 28).

Drill the holes for the two femoral pegs with the patella/femoral drill bit (Figure 29).

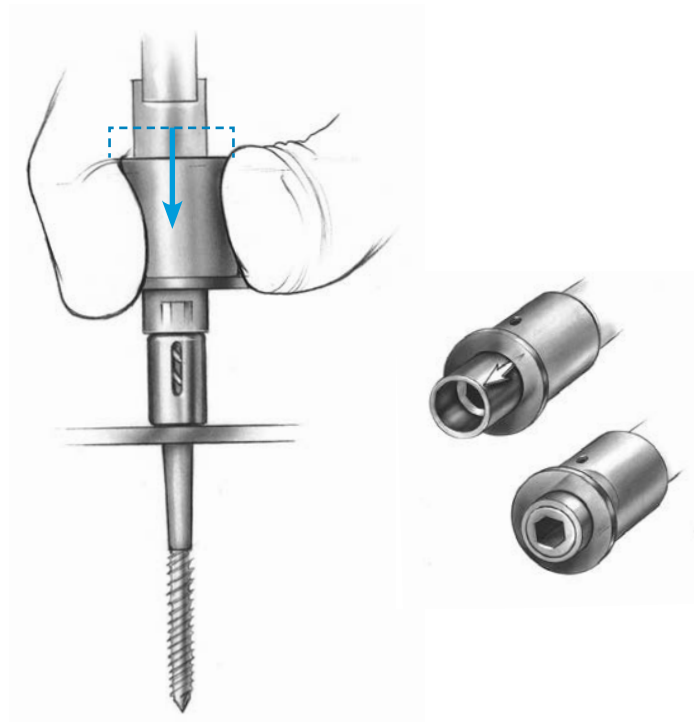

Figure 30

Step Four: Finish the Femur (cont.)

When complete, use the female hex driver to remove the two silver spring pins. Place the hex driver over the spring pin and apply a downward force on the driver sleeve (Figure 30). Start the drill/reamer in reverse, slowly until the driver hex engages the hex-head of the pin. Continue until the spring pin disengages bone.

Use the slaphammer extractor to remove the femoral finishing guide, and use a reciprocating saw to complete the sides of the trochlear recess at the two reference marks.

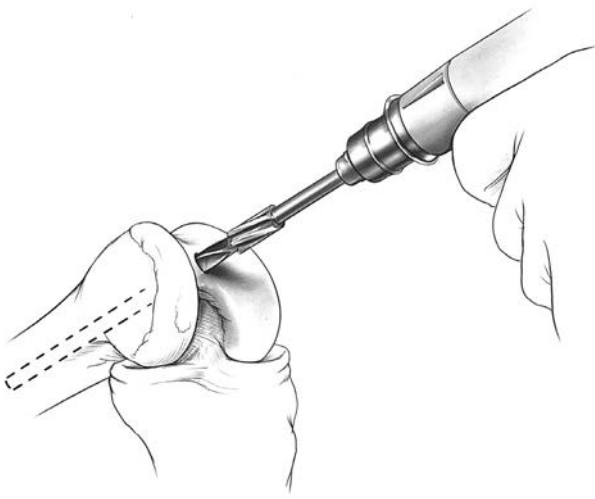

Figure 31

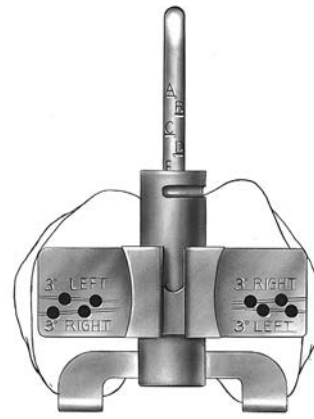

Figure 32

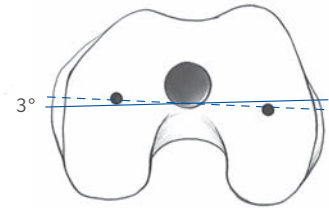
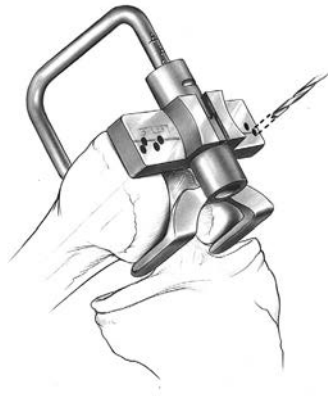

Figure 33

MICRO-MILL/5-in-1 Instrumentation

Step One: Size the Femur

Drill a hole in the center of the patellar sulcus of the distal femur (Figure 31), making sure that the hole is parallel to the shaft of the femur in both the anteroposterior and lateral projections. The hole should be approximately 1 cm anterior to the origin of the posterior cruciate ligament. The drill is a step drill and should be used to enlarge the entrance hole on the femur to 12 mm in diameter if desired. This will reduce further intramedullary pressure from placement of subsequent intramedullary guides.

Insert the IM femoral A/P sizing guide into the hole until it contacts the distal femur. Compress the guide until the anterior boom contacts the anterior cortex of the femur, and both feet rest on the cartilage of the posterior condyles. Placing the guide in flexion or extension can produce inaccurate readings. Check to ensure that the boom is not seated on a high spot, or an unusually low spot.

Read the femoral size directly from the guide (Figure 32). If the indicator is between two sizes, choose the smaller size. This size indicates the proper size of the femoral A/P placement guide, the femoral milling template or 5-in-1 femoral cutting guide, the femoral finishing guide (milling or 5-in-1), and the femoral component. The sizing can be confirmed at the alignment stage.

The IM femoral A/P sizing guide can also be used to aid in setting 3° of external rotation of the femoral component in relation to the nondeformed posterior condyle. Select and drill through the appropriate holes in the guide being sure that the proper “Right” or “Left” indication is used. Drill one hole on each side, medial and lateral. This will place two reference holes on the femur at 3° of external rotation (Figure 33). These holes will be used in conjunction with the Intramedullary alignment guide to set rotation.

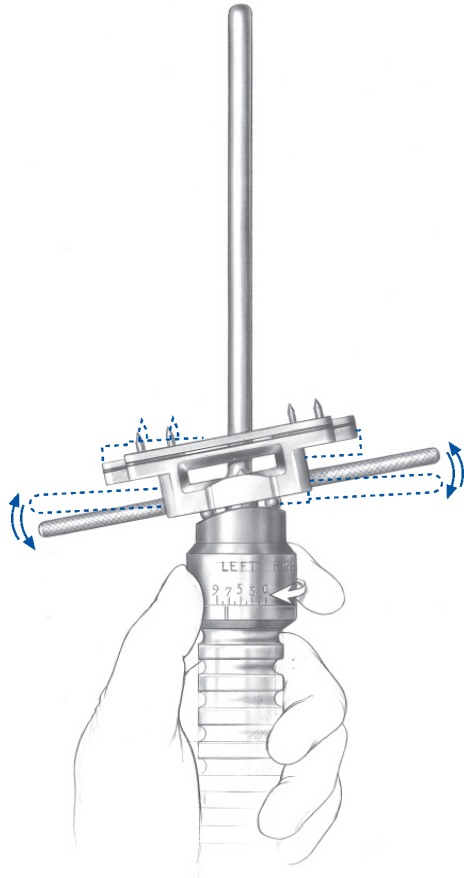

Figure 34

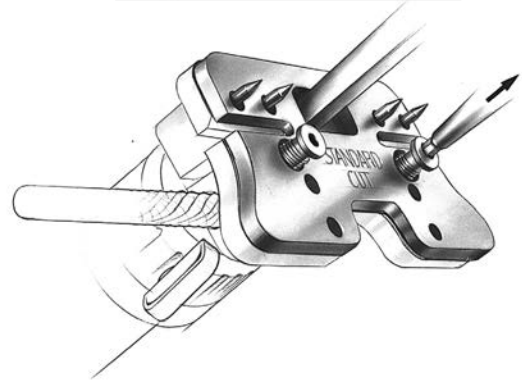
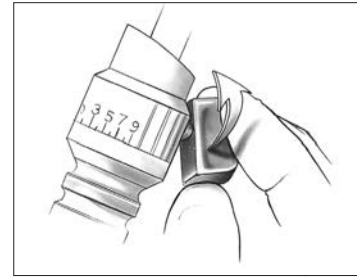

Figure 35

Step Two: Establish Femoral Alignment

In this step, the valgus angle, depth of distal femoral resection, rotation and anterior/posterior (A/P) placement are set.

First, set the intramedullary alignment guide to the proper valgus angle as determined by preoperative radiographs. Check to ensure that the proper “Right” or “Left” indication is used and engage the lock mechanism (Figure 34). The standard cut block must be attached to the intramedullary alignment guide for normal distal femoral resection. The plate should be tightened on the guide prior to use and the screws should be loosened for sterilization. If a large flexion contracture exists or, for other reasons, 3 mm of additional distal femoral bone needs to be resected, remove the standard cut block (Figure 35).

Insert the guide into the intramedullary hole on the distal femur.

Optional Technique

The extramedullary alignment arch and alignment rod can be used to confirm the alignment. If this is anticipated, it is best to identify the center of the femoral head before draping. If extramedullary alignment will be the only mode of alignment, a palpable radiopaque marker should be used in combination with an A/P X-ray film to ensure proper location of the femoral head.

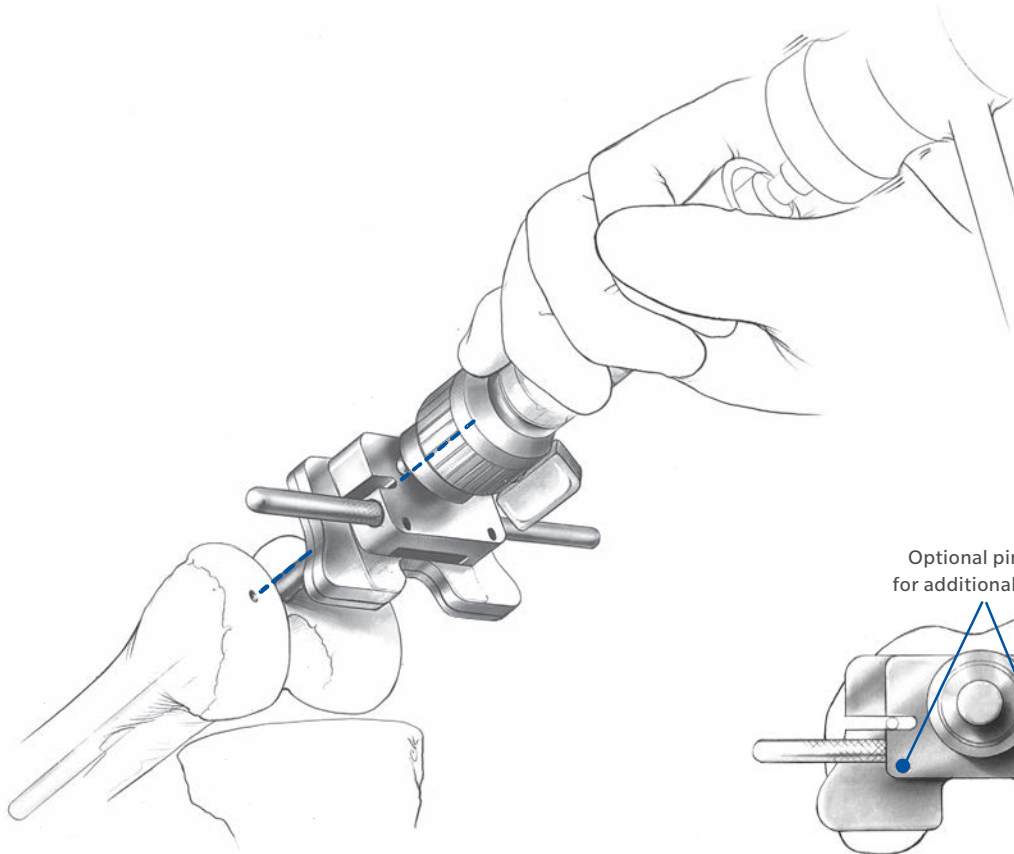

Figure 36

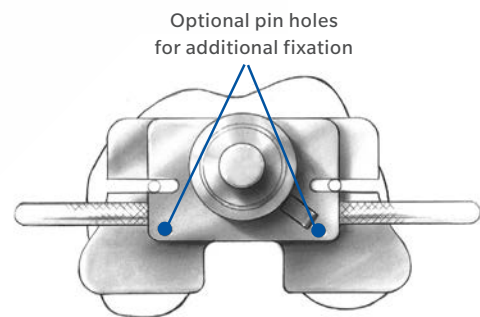

Figure 37

Step Two: Establish Femoral Alignment (cont.)

To achieve 3° of femoral component external rotation, use the alignment holes made when sizing. Line the holes up with the alignment slots on the intramedullary alignment guide (Figure 36). If needed, 1/8-inch pins can be used to aid alignment with the pin going through the alignment slot on the guide and into the alignment holes.

Once the proper external rotation is achieved, impact the intramedullary alignment guide until it seats on the most prominent condyle. After impacting, check to ensure that the valgus setting has not changed. Ensure that the guide is contacting at least one distal condyle. This will set the proper distal femoral resection level.

Optional Technique

The external rotation can also be set by positioning the handles of the intramedullary alignment guide parallel to the epicondyles, or by using the posterior condyles and referencing the posterior aspect of the guide (Figure 37). A rotational alignment guide is available for easier referencing of the posterior condyles in large knees.

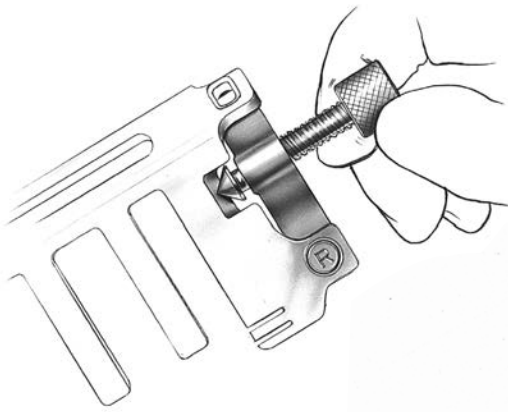

Figure 38

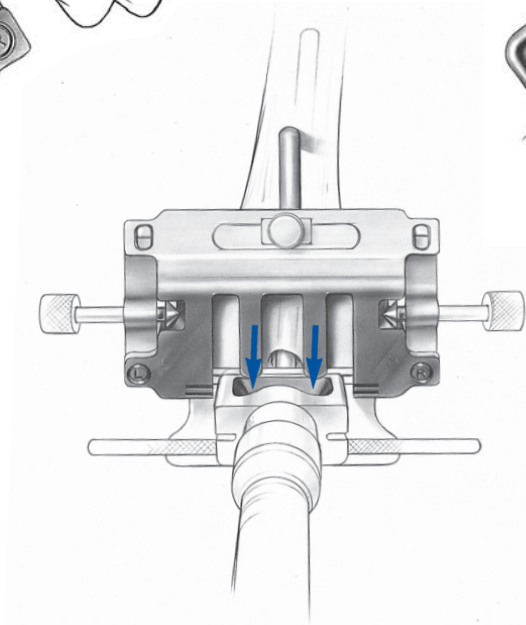

Figure 39

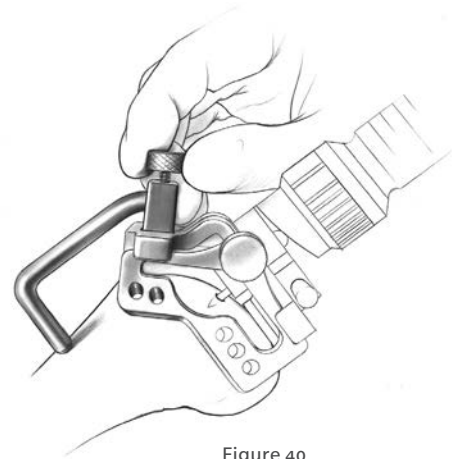

Figure 40

Step Three: Set A/P Position of the Femur

While the intramedullary alignment guide is being inserted by the surgeon, the scrub nurse should attach the two standard femoral mounting bases (Micro sizes require separate bases) to the correct size femoral A/P placement guide as determined in **Step One**. Tighten the thumb screws. The bases are right/left specific with “R” and “L” indications and can only be assembled in the correct orientation (Figure 38).

ⓘ **Note:** The 1/8-inch pins must be removed from the external rotation slots for the femoral A/P placement guide to seat properly.

Insert the femoral A/P placement guide with bases attached into the intramedullary alignment guide (Figure 39) until the boom contacts the anterior femoral cortex.

The boom indicates where the anterior cut will exit the femur. To prevent notching of the femur, center the boom over the medullary canal. Be sure that the boom is not on an unusually high or low spot. If it is, adjust the boom to a more appropriate position. When the boom position is set, tighten the boom thumb screw (Figure 40).

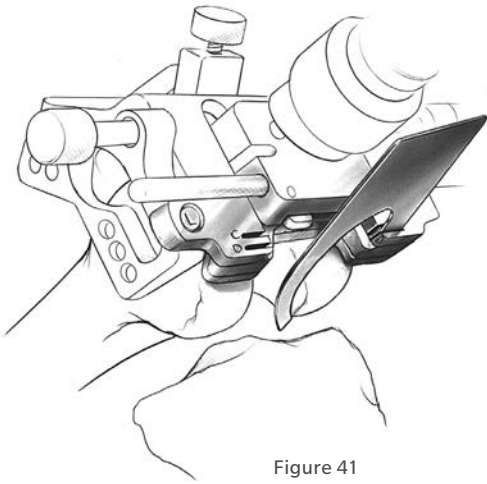

Figure 41

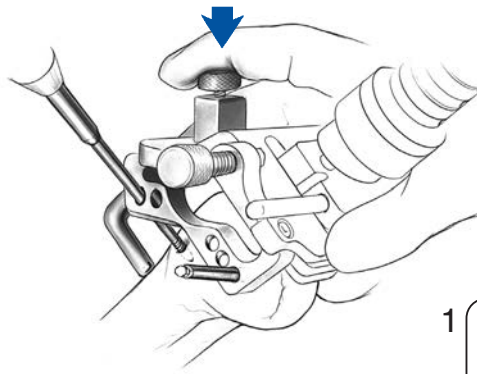

Figure 43

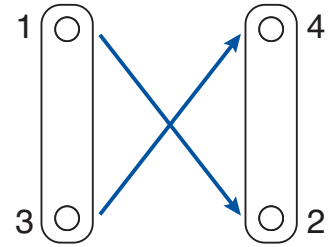

Figure 44

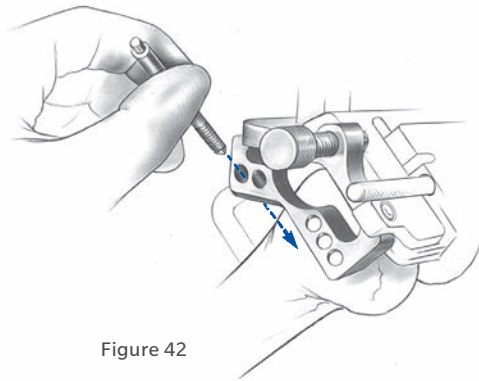

Figure 42

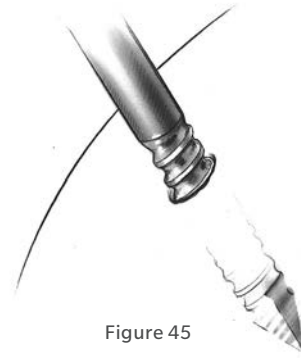

Figure 45

Step Three: Set A/P Position of the Femur (cont.)

The two slots on the posterior aspect of the femoral A/P placement guide correspond to the posterior femoral resection of the two femoral sizes covered by the guide. This resection level can be checked by placing the resection guide through the slots (Figure 41).

ⓘ **Note:** More external rotation typically results in removal of more bone on the medial posterior condyle. Depending on posterior condylar bone loss, this may vary.

If neither of the posterior resection levels are satisfactory, the femoral sizing steps should be re-evaluated.

Step Four: Secure Femoral Mounting Bases

By hand, insert two fixation pins into each side of the two femoral mounting bases. Use the holes that are farthest apart (Figure 42) and do not impinge soft tissue. Then, while holding the boom of the femoral A/P placement guide to ensure that it is still touching the anterior femoral cortex (Figure 43), use the female hex driver and drill/reamer to drive each pin into the bone in the order indicated (Figure 44). The drill/reamer should be set to the "Screw" position. The drill/reamer should be set to the "Screw" position. To prevent galling while screwing a pin in, ensure that the pin remains parallel to the hole. Do not completely bury the threaded portion within the bone. Leave one or two threads visible (Figure 45).

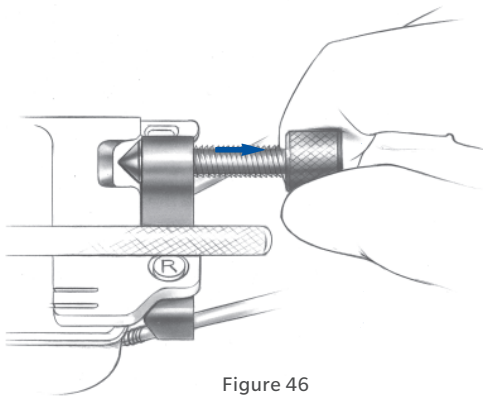

Figure 46

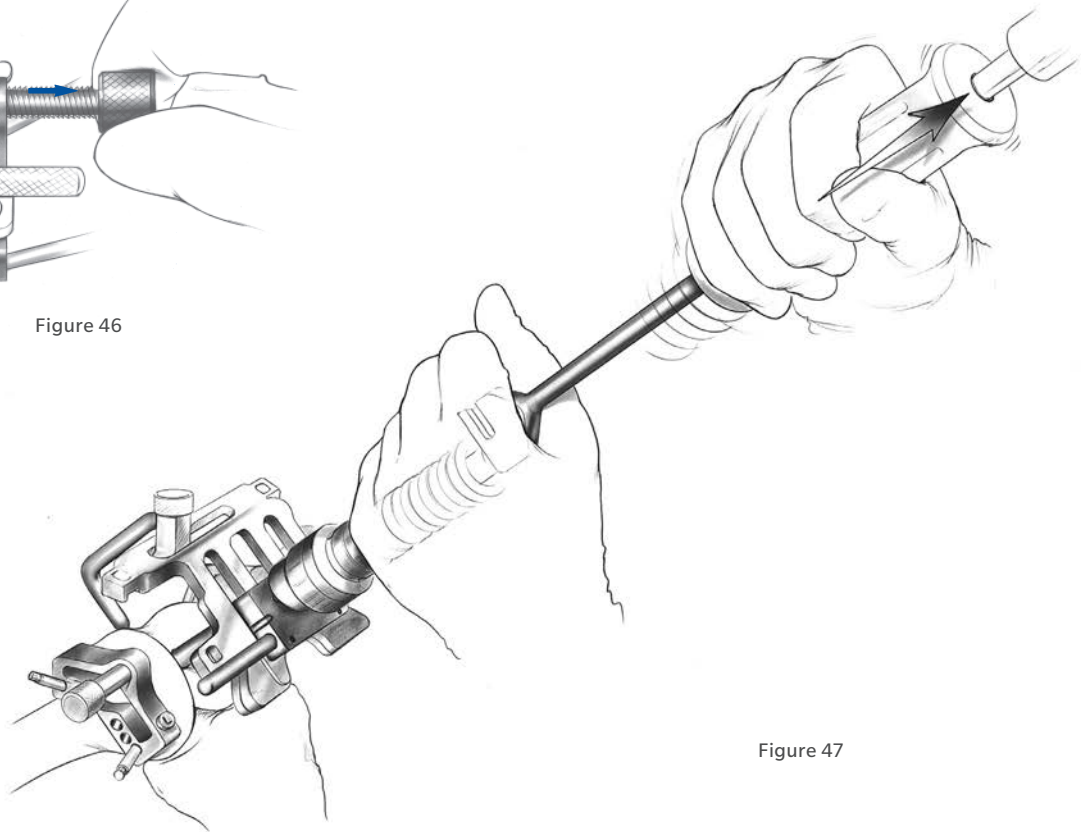

Figure 47

Step Four: Secure Femoral Mounting Bases (cont.)

Loosen the thumb screw that holds the boom of the femoral A/P placement guide in position and slide the boom to the medial side. Then loosen the two thumb screws on the femoral mounting bases until they are completely free of the femoral A/P placement guide (Figure 46).

Remove the placement guide and intramedullary alignment guide with the slaphammer extractor (Figure 47).

The sizing and alignment steps are now complete. All femoral precision cuts will reference off the femoral mounting bases, preventing inaccuracies due to multiple instrument usage and referencing resected surfaces.

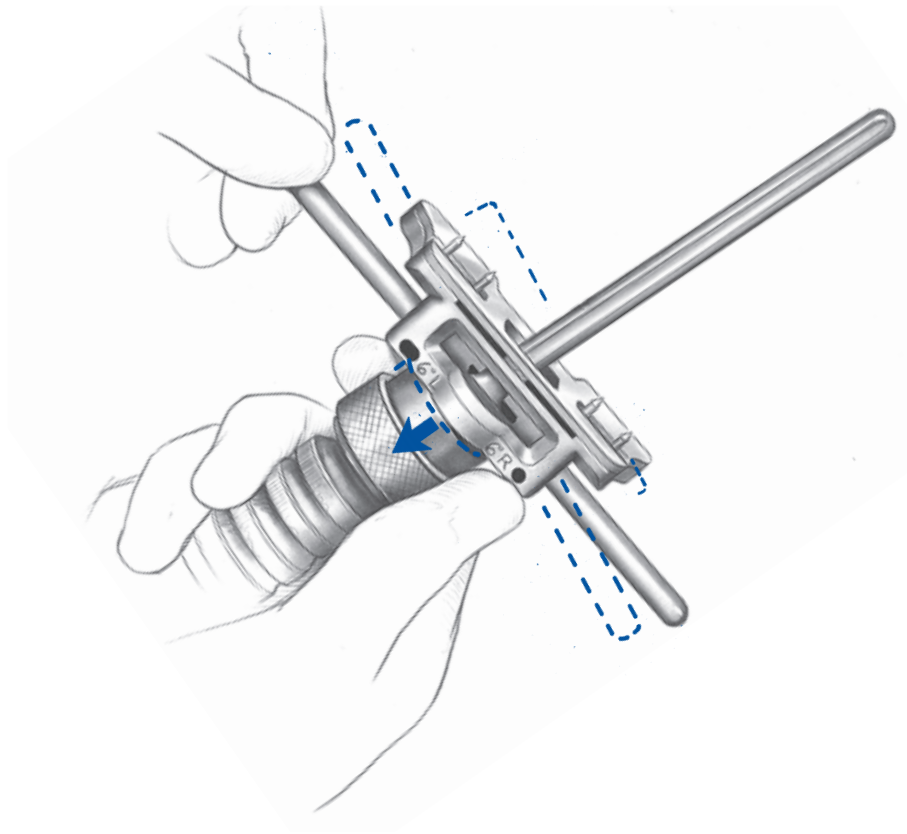

Figure 48

Step Four: Secure Femoral Mounting Bases (cont.)

Optional 4-inch Intramedullary Alignment Guide Technique

If the femoral anatomy is altered, as in a femur with a long-stem hip prosthesis or with a femoral fracture malunion, then the optional 4-inch intramedullary alignment guide should be used. To use the 4-inch guide, pull the sleeve down and rotate the plate to the proper setting “Right” or “Left”. Reference the indication closest to the handle (Figure 48). This sets the guide to a 6° valgus angle. **The extramedullary alignment arch and alignment rods must be used to ensure proper valgus alignment since the shorter rod is not as stable in the medullary canal.** The handle

of the guide should be viewed from the side to ensure the component is not in flexion or extension. The handle of the guide should be parallel to the medullary canal. If it is not, adjust the guide and pin it in place. Once satisfied with the alignment, proceed with the rest of the alignment procedure. To proceed directly to the 5-in-1 technique, please go to page 26.

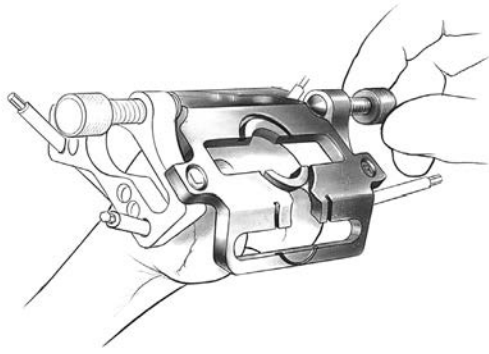

Figure 49

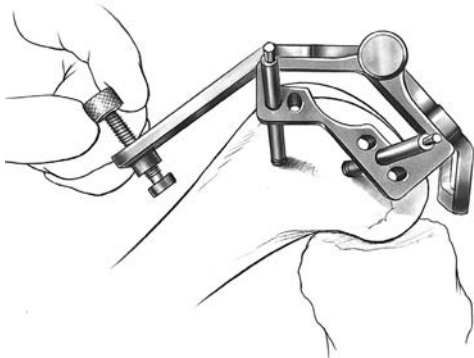

Figure 50



Figure 51

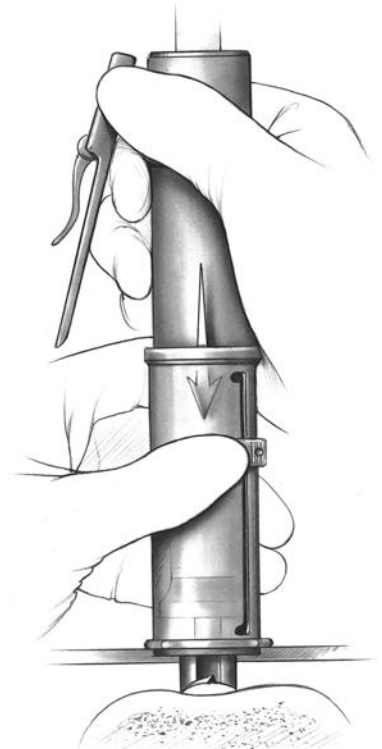

Figure 52

Step Four: Secure Femoral Mounting Bases (cont.)

In the next two steps, femoral resection and femoral finishing, the milling or 5-in-1 saw blade techniques can be used. First, the milling technique will be shown and then the 5-in-1 saw blade technique. To proceed directly to the 5-in-1 technique, please go to page 26.

Step Five (Milling): Femoral Resection

Attach the proper size femoral milling template onto the two femoral mounting bases. If the template contacts the tibia, flex the knee further. Secure the template by turning the thumb screws on the two bases until they lock on the template (Figure 49). To further stabilize the template, turn the anterior screw by hand until it contacts the anterior femoral cortex (Figure 50). Do not overtighten. Check to ensure that there is no soft tissue in the area below the template. The quadriceps muscle and tendon, as well as the patella, must be protected.

Note: The milling depth resection guide can be used at this time to verify that the template is correctly positioned for the proper depth of resection.

With the shield/plunge guide over the cutter, spread the drape over the operative site and insert the shield/plunge guide into the anterior recessed ring on the template (Figure 51).

Disengage the lock on the shield/plunge guide and advance the cutter to the bone (Figure 52).

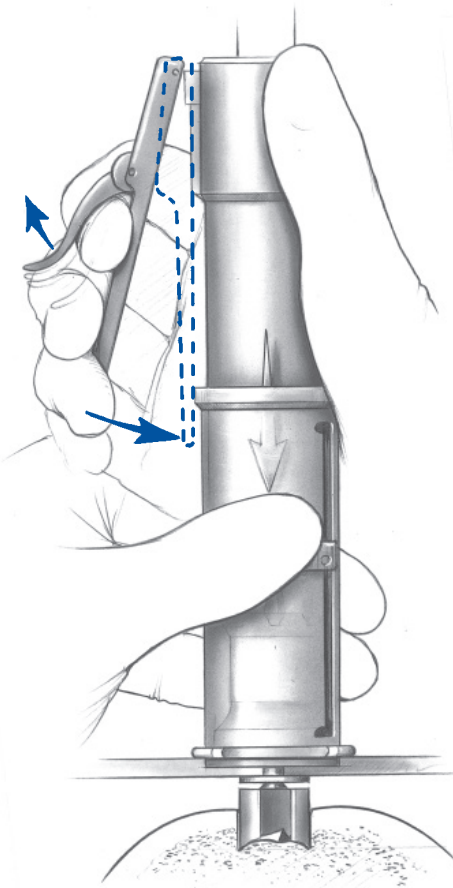

Figure 53

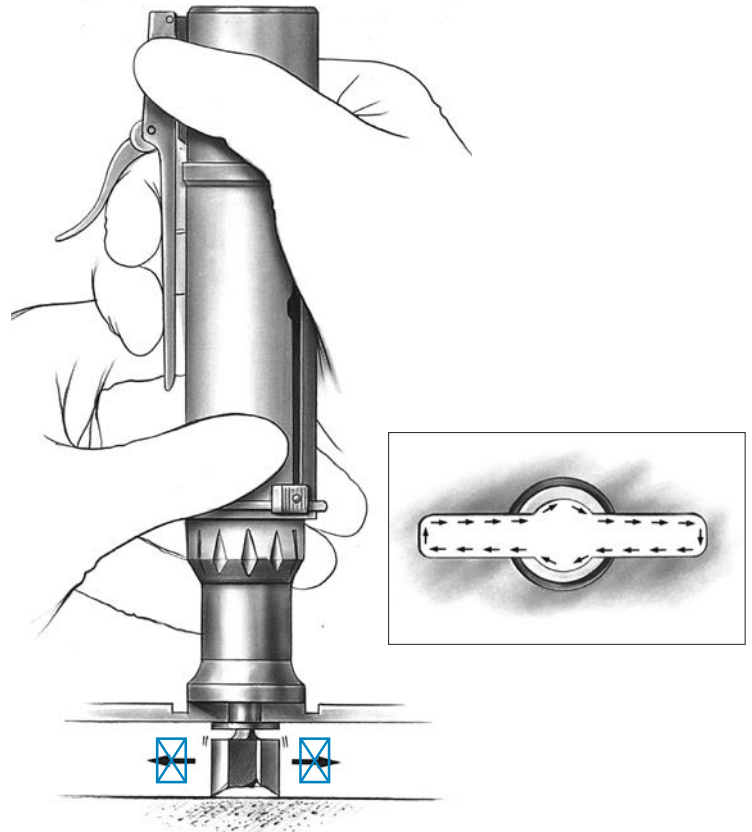

Figure 54

Step Five (Milling): Femoral Resection (cont.)

Turn the Micro-Mill safety off by placing at least one finger under the safety lever. Raise the cutter slightly off the bone by moving the mill only, and leaving the shield/plunge guide engaged in the template. Then, holding the mill firmly with both hands, start the mill by pressing the throttle lever and plunge the cutter into the bone until the nose of the mill rests on the milling template (Figure 53). Retract the shield/plunge guide and move the mill through the track of the template in a clockwise direction, while keeping the mill against the outside edge of the track (Figure 54).

Do not force the mill. Use the lower hand to direct the mill movement. Do not hold the femoral milling template while milling. Keep both hands on the mill, and do not allow any hands under the drape. Also, ensure that no soft tissue is below the template.

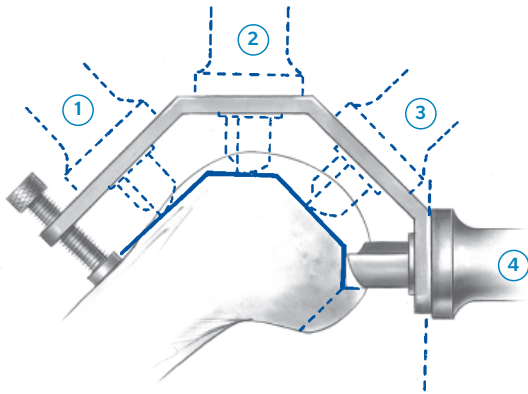

Figure 55

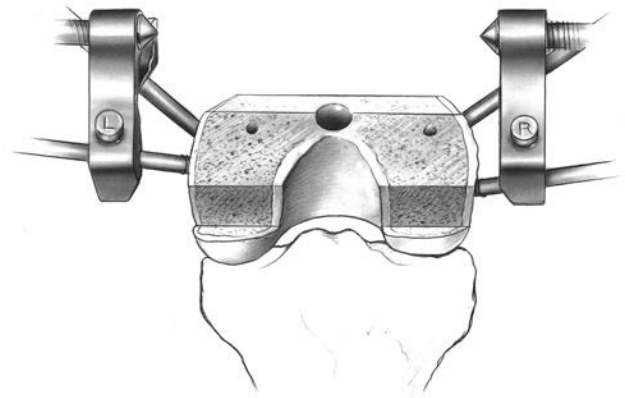

Figure 56

Step Five (Milling): Femoral Resection (cont.)

When each section is complete, turn off the mill and remove it from the track. Pull the shield/plunge guide down to cover the cutter. Repeat the above procedure for each of the template tracks, moving from anterior to posterior. The milling procedure can be stopped at any time. The mill and template can be removed to provide a clear view of the milled surface, then reattached to complete the milling without loss of accuracy.

The posterior chamfer region is the most difficult section to mill. This region does not fully support the shield/plunge guide, so care must be taken to ensure that the mill is perpendicular to the femoral milling template when inserting the mill into the template and when milling (Figure 55). Often, one will not need to use the shield/plunge guide. The mill can engage the template centrally without contacting the bone.

When all four sections have been milled, remove the mill and template. Check the surfaces of the milled bone (Figure 56). If milling is complete, proceed to **STEP SIX**. If any areas are unmilled, reattach the femoral milling template and remill the unfinished sections. In some cases, there may be a small step on the anterior cortex since the mill is contained in the template, preventing the cut from extending up the femur. If so, blend it into the anterior cortex with a saw or file.

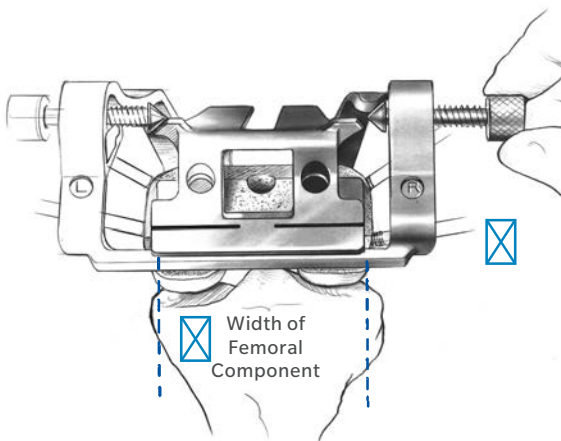

Figure 57

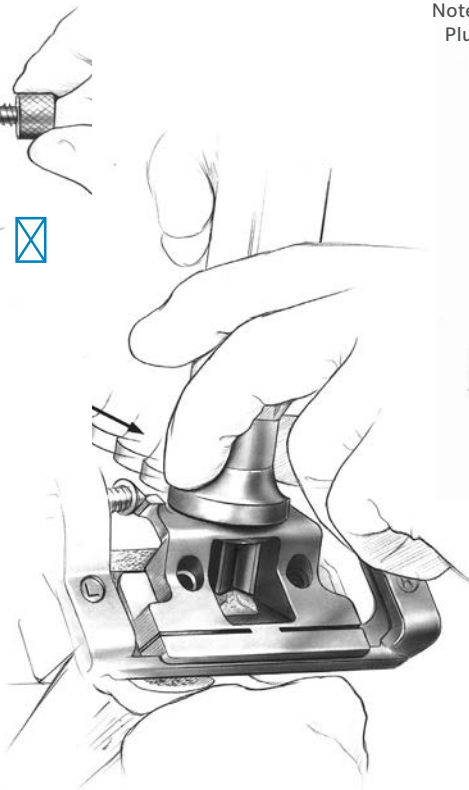

Figure 58

Step Six (Milling): Finish the Femur

Place the appropriate size femoral finishing guide onto the femoral mounting bases. Center the guide mediolaterally on the distal femur. Use the mounting base thumb screws for final mediolateral adjustment and secure the guide by tightening both thumb screws (Figure 57).

The width of the guide equals the distal width of the femoral component. The position of the guide will determine the position of the implant. Ensuring that the guide does not move, secure the guide to the mounting bases by tightening both thumb screws.

With the milling drape in place and the shield/plunge guide retracted (plunge cut not required), engage the mill into the anterior track of the guide (Figure 58). Disengage the mill safety and start the mill with the cutter slightly off the bone. Then, holding the mill firmly with both hands and perpendicular to the track, mill the trochlear recess. Move the mill clockwise within the track, keeping the mill pressed against the outside edge (Figure 59). Remove the mill and pull the shield/plunge guide back over the cutter.

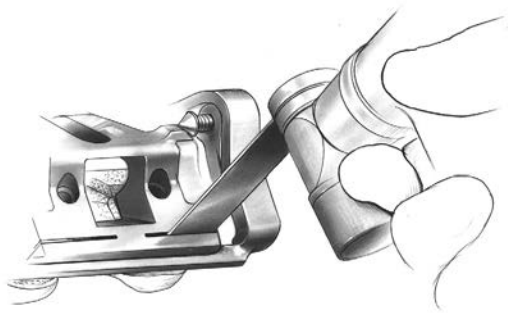

Figure 60

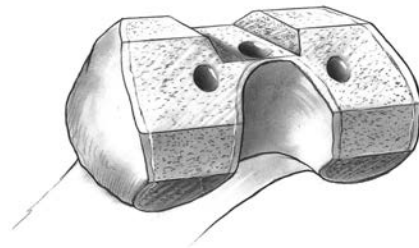

Figure 62

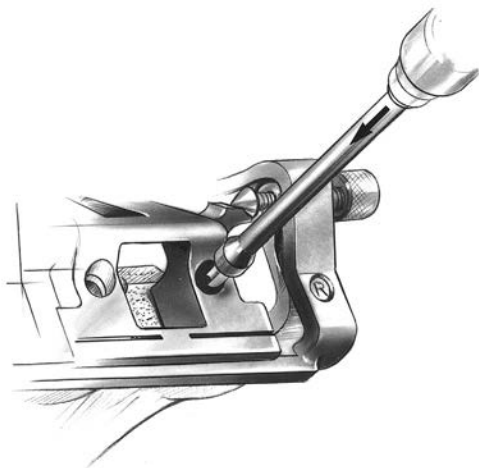

Figure 61

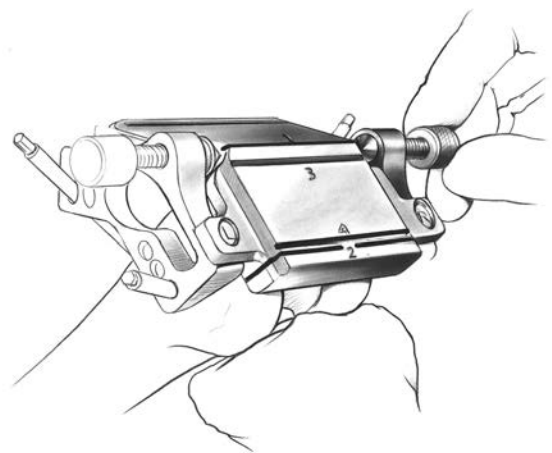

Figure 63

Use the appropriate thickness (0.050-inch/1.27 mm) blade and an oscillating saw to cut the posterior condyles (Figure 60). Ensure that the proper thickness blade is used to yield the optimum cut and implant fit. Drill the two femoral post holes (Figure 61). Remove the femoral finishing guide. Ensure that all cuts are complete before removing the two femoral mounting bases (Figure 62).

Step Five (5-in-1): Femoral Resection

Attach the proper size 5-in-1 femoral cutting guide onto the two femoral mounting bases. If the guide does not seat, check for and remove any osteophytes or bone that is causing interference. Lock the cutting guide into position by firmly turning the thumb screws on the two bases (Figure 63). Check to be sure that there is no soft tissue in the area below the guide.

ⓘ **Note:** If template is not firmly locked into position, vibration can loosen the thumb screws.

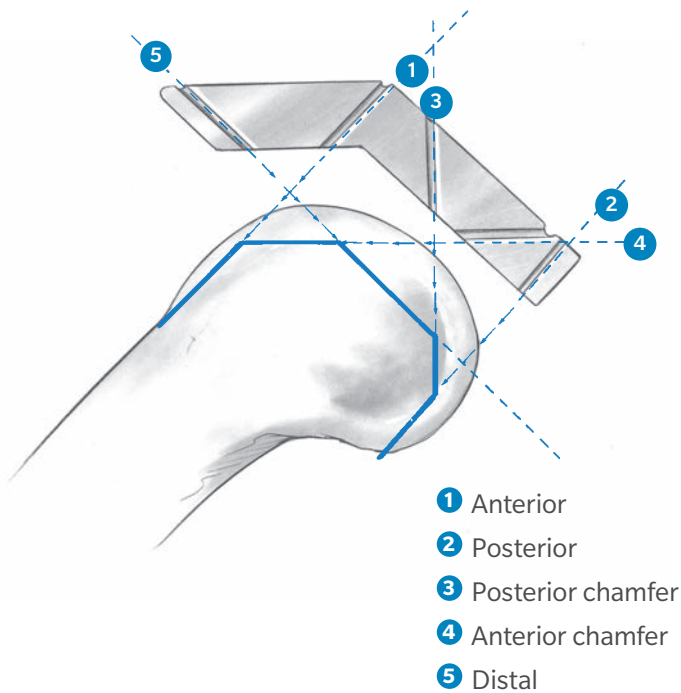

Figure 64

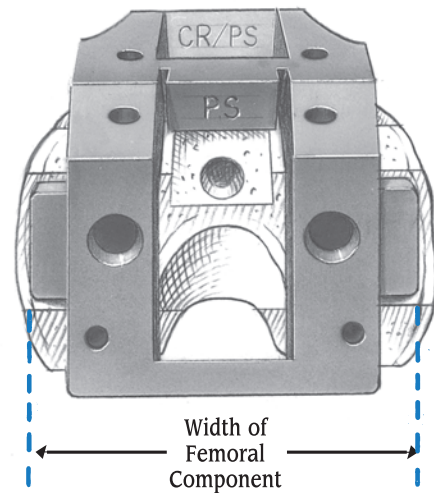

Figure 65

Step Five (5-in-1): Femoral Resection (cont.)

For the most accurate cuts, perform the femoral cuts through the slots in the order indicated on the guide (Figure 64).

The guide can be removed at any time to check the cuts and be reattached to the bases to finish the cuts without loss of accuracy. For precision cuts, one must use the appropriate thickness (0.050-inch/1.27 mm) saw blade. When all cuts are complete, remove the 5-in-1 femoral cutting guide and the femoral mounting bases.

Step Six (5-in-1): Finish the Femur

Place the appropriate size 5-in-1 finishing/notch guide onto the femur. It will rest on the resected surface of the anterior and distal femur. The guide will not contact the anterior chamfer. Center the guide mediolaterally on the distal femur (Figure 65). The width of the guide equals the distal width of the femoral component.

This will determine the position of the femoral component. Secure the guide to the femur with two spring pins using the female hex driver and drill/reamer. The pins are designed to automatically disengage the driver when fully engaged on the guide.

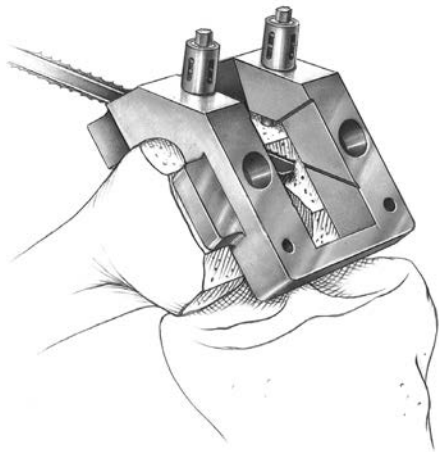

Figure 66

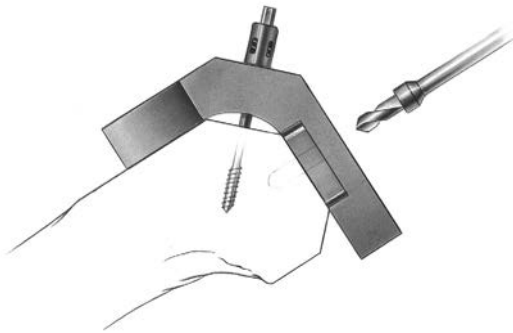

Figure 67

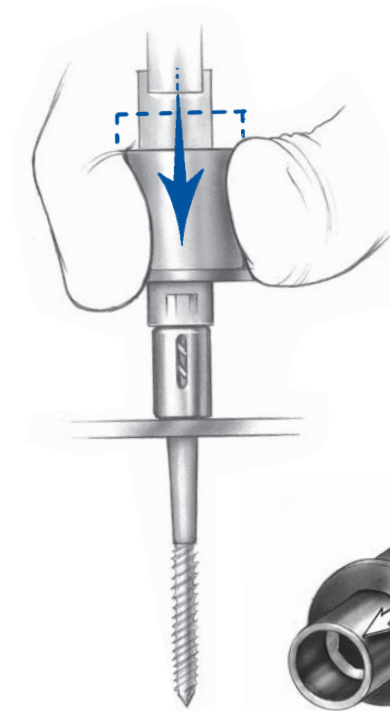

Figure 68



Optional Technique

The 5-in-1 finishing/notch guide can also be attached with standard 1/8-inch pins through the holes in the anterior and distal portion of the guide. Ensure that the proper size holes are selected for the spring pins or 1/8-inch pins.

Use a reciprocating saw to first cut the base and then the sides of the trochlear recess. The engraved lines on the inside of the guide show the depth of the trochlear recess (Figure 66). Cut only the trochlear recess for CR components. The cutting surface on the guide is marked “CR/PS.”

Optional Technique

An oscillating saw with a small width blade may also be used, or a normal blade to cut the sides and a chisel or osteotome to cut the base of the recess.

Drill the two femoral post holes (Figure 67).

Place the female hex driver over the spring pin and apply a downward force on the driver sleeve (Figure 68). Start the drill/reamer slowly until the driver hex engages the hex head of the pin. Continue until the spring pin disengages bone.

Remove the 5-in-1 finishing/notch guide.

“Crossover” Technique

(When crossing over to a posterior stabilized design)

Introduction

While the NexGen CR and LPS box cuts are the same, the techniques have some differences that are important to consider when moving from a cruciate retaining to a posterior stabilized implant. A posterior stabilized technique uses spacer blocks and/or tensor devices to balance flexion and extension gaps. Posterior referencing instrumentation systems, such as the Multi-Reference 4-in-1 femoral instrumentation system, are designed to help balance the gaps with the initial bone cuts. Balancing the flexion and extension gaps is different between the two procedures because, when the PCL is resected, the flexion gap increases 3 mm to 5 mm, but the extension gap typically increases less.

Most anterior referencing techniques recommend downsizing when the size indicated is between two sizes. Downsizing increases the flexion gap and is well-accepted when using a cruciate retaining implant because the PCL tethers the joint in flexion. However, when using a posterior stabilized implant, surgeons are advised to use the next largest size implant when the measurement is between two sizes. This will still allow them to downsize if the knee is too tight in flexion with the larger size.

The posterior slope of the tibial cut also affects the joint space in flexion. For a cruciate retaining implant, cutting a greater posterior slope on the tibia simply relieves the tightness of the knee in flexion. But for a posterior stabilized implant, a greater posterior slope can result in a larger flexion gap. Some surgeons who follow the posterior stabilized philosophy choose to cut a posterior slope that matches the preoperative slope of the tibia, usually in the range of 3°- 7°.

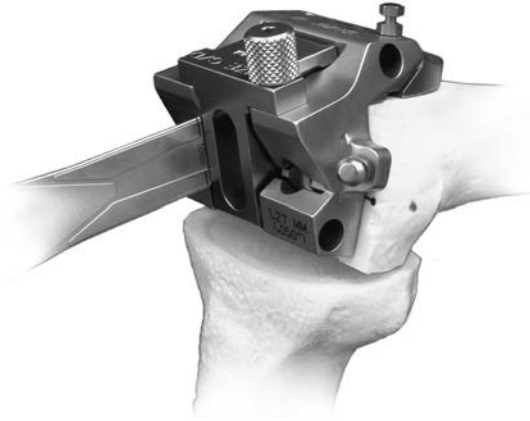

Figure 69

“Crossover” Technique

Epicondylar Notch/Chamfer Guide

Place the epicondylar notch/chamfer guide flush with the anterior and distal surfaces of the femur. Use the previously prepared trochlear recess and/or femoral peg holes to locate the guide mediolaterally. Pin the guide to the femur and use the appropriate saw to cut the sides of the notch (Figure 69). Then use an osteotome to remove the notch.

5-in-1 Finishing/Notch Guide

Place the appropriate size 5-in-1 finishing/notch guide onto the femur. It will rest on the resected surface of the anterior and distal femur. The guide will not contact the anterior chamfer. Use the previously prepared trochlear recess and/or femoral peg holes to locate the guide.

Secure the guide to the femur with two short-threaded silver spring pins using the female hex driver and drill/reamer. The pins are designed to automatically disengage the pin driver when fully engaged on the guide.

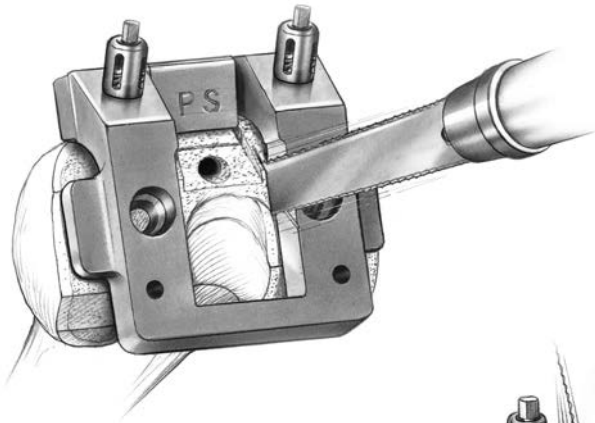

Figure 70

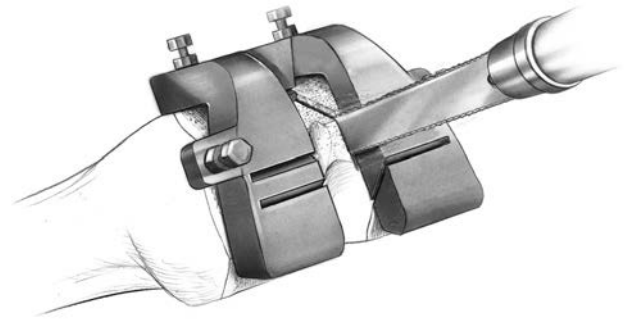

Figure 72

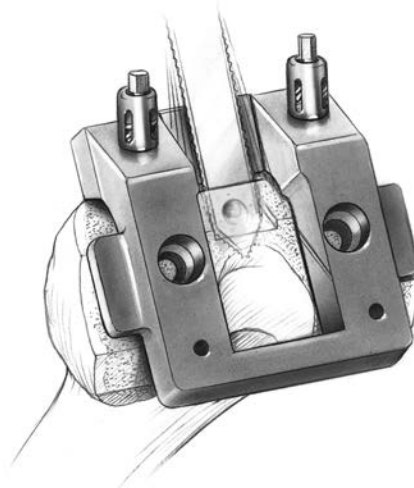

Figure 71

Optional Technique

The guide can also be attached with standard 1/8-inch pins through the holes in the anterior and distal portion of the guide. Ensure that the proper size holes are selected for the spring pins or 1/8-inch pins.

Use a reciprocating saw to cut the sides (Figure 70) and the base (Figure 71) of the intercondylar notch. The cutting surface of the guide is marked "PS."

Optional Technique

An oscillating saw with a small width blade may also be used. Or use a normal blade to cut the sides and a chisel or osteotome to cut the base of the recess.

Remove the finishing/notch guide

Notch/Chamfer Guide

Place the notch/chamfer guide on the cut surface of the distal femur with the anterior tab resting in the trochlear recess. Pin the guide to the bone and use a saw to cut the sides of the notch (Figure 72). Then use an osteotome to remove the notch.

Tibial Preparation for Primary Arthroplasty



Figure 73



Figure 75

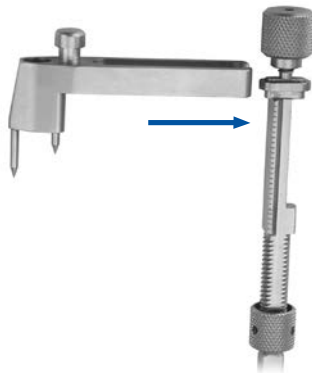

Figure 74



Figure 76

Spike Arm Extramedullary Technique

Step One: Assemble Alignment Guide

Slide the ankle clamp onto the dovetail at the bottom of the distal telescoping rod. Turn the knob opposite the dovetail to temporarily hold the clamp in place (Figure 73). The mediolateral position of the rod can be adjusted by loosening this knob. When the final position is determined, the knob can be fully tightened to secure it in place.

Slide the spike arm onto the dovetail at the top of the spike arm telescoping rod and temporarily secure it by turning the knob at the top of the rod (Figure 74).

The system includes four different cut guides: a 7° guide and a 0° guide both in left and right configurations.

Lower the adjustment knob in the middle of the spike arm telescoping rod to the bottom of the threaded portion. Insert the cut guide over the threaded portion of the rod above the adjustment knob and slide it all the way up on the dovetail (Figure 75). To hold the cut guide in place, advance the adjustment knob to the upper end of its range of travel. This will allow for space adjustment after the alignment guide assembly has been secured in position.

Arrows are etched onto both the spike arm telescoping rod and the distal telescoping rod to indicate the correct orientation during assembly (Figure 76). Insert the spike arm telescoping rod into the distal telescoping rod.



Figure 77



Figure 78

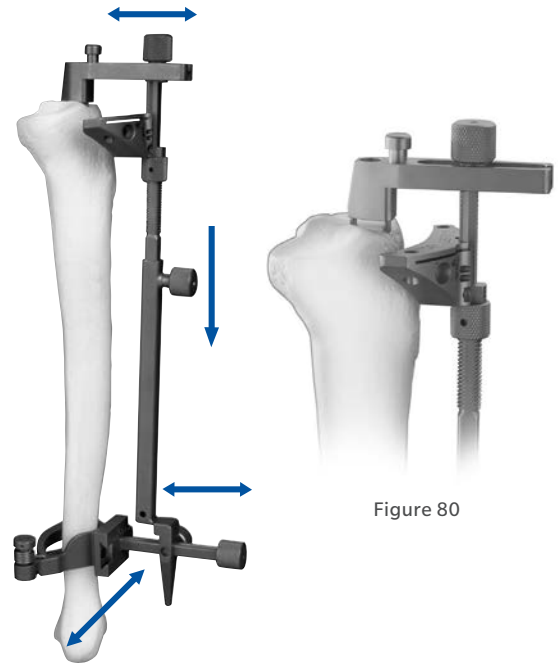

Figure 79



Figure 80

Step Two: Position Alignment Guide

To improve exposure of the tibial surface, use the tibial retractor to lever the tibia anteriorly. This instrument should be carefully positioned against the posterior cortex of the tibia subperiosteally to prevent neurovascular injury. Use the patella retractor to retract the patella laterally. Adjust the telescoping rod to the approximate length of the tibia and turn the knob on the shaft to temporarily maintain the length. Place the spring arms of the ankle clamp around the ankle proximal to the malleoli (Figure 77) and loosen the knob that provides mediolateral adjustment at the ankle.

Position the cut guide at the proximal tibia. Loosen the knob in the middle of the telescoping rod and adjust the length of the rod until the long spike on the spike arm just contacts the tibial plateau. The cut guide should be proximal to the tibial tubercle. Center the long spike mediolaterally on the bone surface anterior to the tibial spine. This should align the rod with the medial third of the tibial tubercle. Stabilize the alignment guide by tapping the spike arm until only the long spike engages the tibial plateau.

Do not drive the long spike in too far (Figure 78).

Adjust the slide at the foot of the rod mediolaterally so the guide is aligned with the mechanical axis of the tibia. The longitudinal axis of the rod will usually lie just medial to the midpoint of the tibial tubercle and be centered over the intercondylar eminence. The foot of the rod should be positioned about 5 mm-10 mm medial to the midpoint between the palpable medial and lateral malleoli. The tip should point to the second toe. When the proper mediolateral position is achieved, tighten the knob to secure the ankle clamp to the rod.

In the sagittal plane, align the rod so it is parallel to the anterior tibial shaft by using the slide adjustments at both the proximal and distal ends of the rod (Figure 79). Then tighten the knobs for both adjustments. If there is a bulky bandage around the ankle, adjust the rod to accommodate the bandage. This will help ensure that the tibia will be cut with the proper slope.

Set the final position of the extramedullary alignment guide assembly by tapping the spike arm until both the long and short spikes are fully impacted in the proximal tibia (Figure 80). Then tighten the knob in the middle of the telescoping rod assembly.

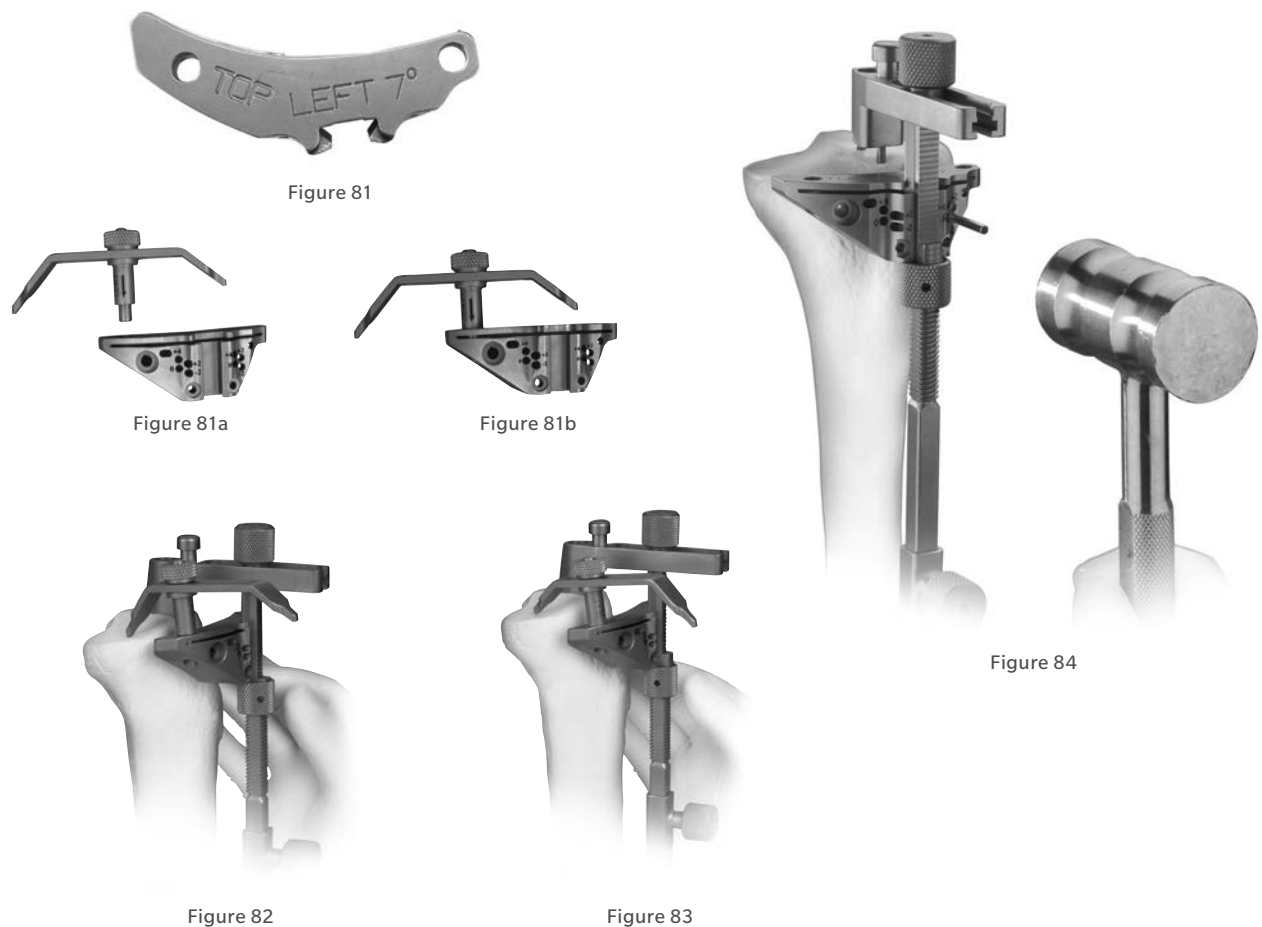

Figure 81

Figure 81a

Figure 81b

Figure 82

Figure 83

Figure 84

Step Three: Set Resection Level

Each tip of the tibial depth resection stylus indicates a different depth. The 2 mm tip is used to check the depth from the defective tibial condyle for a minimal cut. The 10 mm tip is used to check the depth from the least involved tibial condyle for an anatomic cut.

Insert the tibial depth resection stylus into the top of the cut guide, using the hole that corresponds to the defective tibial condyle (Figure 81).

The stylus will snap into the hole (Figure 81a, Figure 81b). Confirm that it is fully seated and properly oriented. The 2 mm tip should rest on the tibial condyle (Figure 82). This positions the slot of the cut guide to remove 2 mm of bone below the tip of the stylus.

Alternatively, rest the 10 mm tip of the stylus on the cartilage of the least involved condyle (Figure 83).

This will allow the removal of the same amount of bone that the thinnest tibial component would replace.

These two points of resection will usually not coincide. The surgeon must determine the appropriate level of resection based on patient age, bone quality, and the type of prosthetic fixation planned.

Adjust the cut guide to the desired depth by turning the adjustment knob. Then insert a 75 mm headless holding pin into the hole marked "0" on one side of the guide (Figure 84).



Figure 85

Step Three: Set Resection Level (cont.)

To confirm alignment, insert the extramedullary alignment arch onto the cut guide and insert the alignment rod with coupler through the arch, passing it distally toward the ankle. The distal end of the rod should point to the second toe (Figure 85).



Figure 86



Figure 87

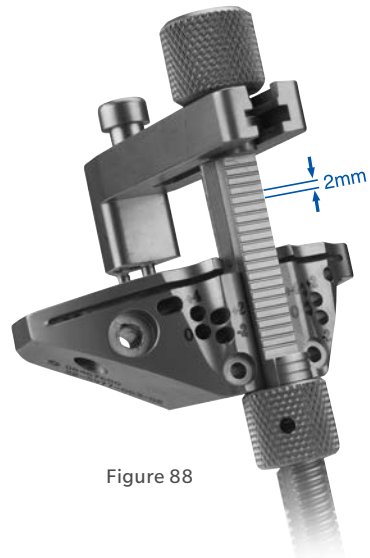

Figure 88

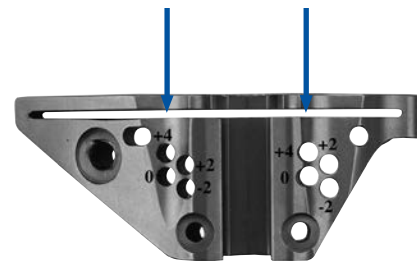

Figure 89

Step Four: Resect the Proximal Tibia

Loosen the adjustment knob below the cut guide until the knob is at the bottom of the threaded portion of the rod. Then loosen the knob on the telescoping rod. Use a saphammer to disengage the spikes on the spike arm. Raise the telescoping rod until the dovetail disengages the cut guide. Then open the arms of the ankle clamp and remove the entire assembly, leaving the cut guide in place on the bone.

If desired, the alignment arch and alignment rod with coupler can be used on the cut guide again to check alignment.

Two mm adjustments may be made by using the sets of holes marked -2, +2, and +4. The markings on the cut guide indicate, in millimeters, the amount of bone resection each will yield relative to the standard tibial resection set by the cut guide and tibial depth resection stylus. Once the tibial resection has been determined, use the hex-head holding pins or silver spring pins to further stabilize the guide.

Use a 0.050-Inch/1.27 mm oscillating saw blade through the slot on the cut guide to cut the proximal surface of the tibia flat (Figure 86). Then remove the cut guide.

Optional Technique

If desired, the cut can be made from the top surface of the cut guide. The top surface of the guide is 4 mm above the slot (Figure 87), so the position of the guide must be adjusted to account for this difference. The adjustment can be made when the cut guide is first positioned by using the etch lines, which are in 2 mm increments, at the top of the spike arm telescoping rod (Figure 88).

Alternatively, the adjustment can be made after the alignment guide assembly is removed by lifting the cut guide off the headless pins, which were inserted through the holes marked "0," and reinserting the guide through the holes marked "+4" (Figure 89).

Proceed to "Finish the Tibia" on page 59.

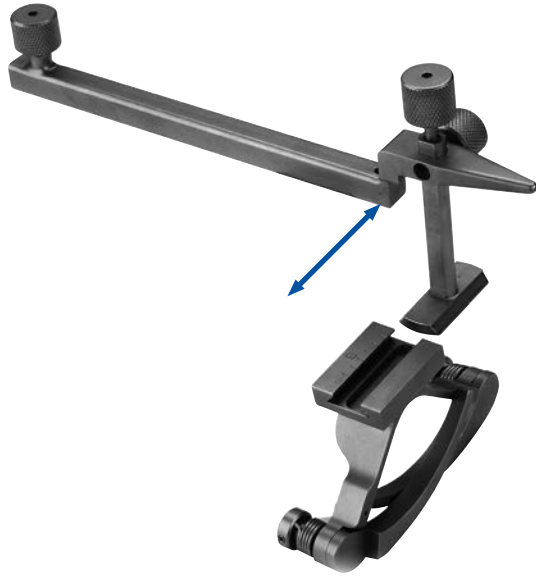

Figure 90



Figure 91



Figure 92

Cut Guide Extramedullary Technique

Step One: Assemble Alignment Guide

Slide the ankle clamp onto the dovetail at the bottom of the distal telescoping rod. Turn the knob opposite the dovetail to temporarily hold the clamp in place (Figure 90). The mediolateral position of the rod can be adjusted by loosening this knob. When the final position is determined, the knob can be fully tightened to secure it in place.

The system includes four different cut guides: a 7° guide and a 0° guide, both in left and right configurations.

Place the desired cut guide onto the dovetail of the proximal portion of the cut guide telescoping rod. Tighten the knob to secure the position (Figure 91).

Arrows are etched onto both the cut guide telescoping rod and the distal telescoping rod to indicate the correct orientation during assembly (Figure 92). Insert the cut guide position alignment guide.



Figure 93



Figure 94



Figure 95

Step Two: Position Alignment Guide

To improve the exposure of the tibial surface, use the tibial retractor to lever the tibia anteriorly. This instrument should be carefully positioned against the posterior cortex of the tibia subperiosteally to prevent neurovascular injury. Use the patella tendon retractor to retract the patella laterally.

Adjust the telescoping rod to the approximate length of the tibia and turn the knob on the shaft of the rod to temporarily maintain the length.

Place the spring arms of the ankle clamp around the ankle proximal to the malleoli (Figure 93) and loosen the knob that provides mediolateral adjustment at the ankle.

Position the cut guide at the proximal tibia. Loosen the knob in the middle of the telescoping rod and adjust the length of the rod until the cut guide is proximal to the tibial tubercle. Align the rod with the medial third of the tibial tubercle (Figure 94) or just medial to the tubercle.

Adjust the slide at the foot of the rod mediolaterally so the guide is aligned with the mechanical axis of the tibia (Figure 95). The longitudinal axis of the rod will usually lie just medial to the midpoint of the tibial tubercle and be centered in line with the intercondylar eminence. The foot of the rod should be positioned about 5 mm-10 mm medial to the midpoint between the palpable medial and lateral malleoli. The tip should point to the second toe. When the proper mediolateral position is achieved, tighten the knob to secure the ankle clamp to the rod. The posterior cortex of the tibia can also be used as a rotational check.

In the sagittal plane, align the rod so it is parallel to the anterior tibial shaft by using the slide adjustment at the distal end of the rod. Tighten the knob for the adjustment. If there is a bulky bandage around the ankle, adjust the rod to accommodate the bandage. This will help ensure that the tibia will be cut with the proper slope.



Figure 96



Figure 96a



Figure 96b



Figure 97

Step Three: Set Resection Level

Each tip of the tibial depth resection stylus indicates a different depth. The 2 mm tip is used to guide the depth from the defective tibial condyle for a minimal cut. The 10 mm tip is used to guide the depth from the least involved tibial condyle for an anatomic cut.

Insert the tibial depth resection stylus into the top of the cut guide, using the hole that corresponds to the defective tibial condyle (Figure 96).

The stylus will snap into the hole (Figures 96a and 96b). Confirm that it is fully seated and properly oriented. The 2 mm tip should rest on the tibial condyle (Figure 97). This positions the slot of the cut guide to remove 2 mm of bone below the tip of the stylus.

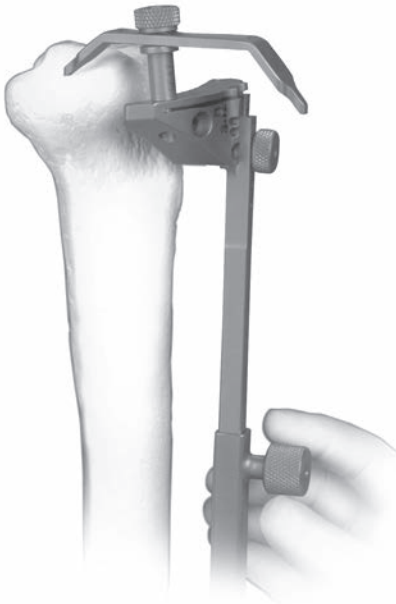

Figure 98



Figure 99



Figure 100

Step Three: Set Resection Level (cont.)

Alternatively, rest the 10 mm tip of the stylus on the cartilage of the least involved condyle (Figure 98).

This will allow the removal of the same amount of bone that the thinnest tibial component would replace.

These two points of resection will usually not coincide. The surgeon must determine the appropriate level of resection based on patient age, bone quality, and the type of prosthetic fixation planned.

Adjust the cut guide to the desired depth by adjusting the length of the alignment guide assembly. Then retighten the telescoping rod, and insert a 75 mm headless holding pin into the hole marked "0" on one side of the cut guide.

To confirm alignment, insert the extramedullary alignment arch into the cut guide and insert the alignment rod with coupler through the arch, passing it distally toward the ankle (Figure 99). The distal end of the rod should point to the second toe.

Insert a second 75 mm headless holding pin into the other hole marked "0" (Figure 100).



Figure 101



Figure 102

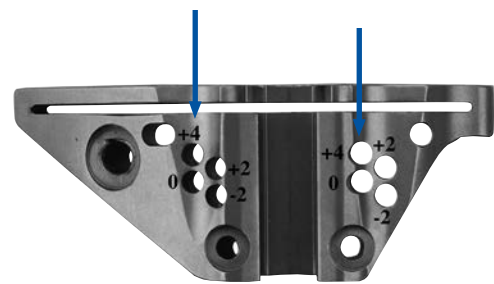

Figure 103

Step Four: Resect the Proximal Tibia

Loosen the knob that has secured the cut guide onto the cut guide telescoping rod and remove the entire assembly, leaving the cut guide in place on the bone.

Additional 2 mm adjustments may be made by using the sets of holes marked -2, +2, and +4. The markings on the cut guide indicate, in millimeters, the amount of bone resection each will yield relative to the standard tibial resection set by the cut guide and tibial depth resection stylus. Once the tibial resection has been determined, use the hex-head holding pins or silver spring pins to further stabilize the guide.

Use a 0.050-Inch/1.27 mm oscillating saw blade through the slot on the cut guide to cut the proximal surface of the tibia flat (Figure 101). Then remove the cut guide.

Optional Technique

If desired, the cut can be made from the top surface of the cut guide. The top surface of the guide is 4 mm above the slot (Figure 102), so the position of the guide must be adjusted to account for this difference. The adjustment can be made after the alignment guide assembly is removed by lifting the cut guide off the headless pins, which were inserted through the holes marked "0," and reinserting the guide through the holes marked "+4" (Figure 103).

Proceed to "Finish the Tibia" on page 59.

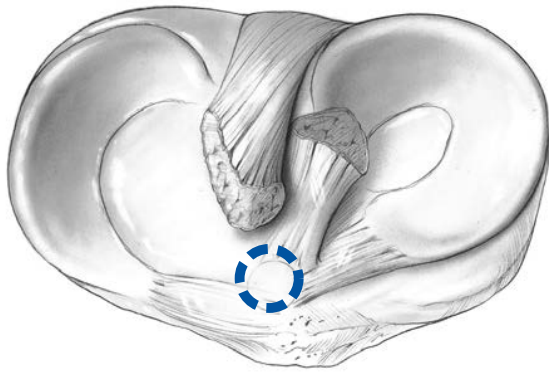

Figure 104



Figure 105

CutGuide Intramedullary Technique

To improve exposure of the tibial surface, use the tibial retractor to lever the tibia anteriorly. This instrument should be carefully positioned against the posterior cortex of the tibia subperiosteally to prevent neurovascular injury. Use the patella tendon retractor to retract the patella laterally.

A preoperative radiograph of the tibia is necessary to make sure that the tibial shaft is straight and will accept the tibial im rod. **Some tibias are bowed or have too small a canal and will not accept the rod. The acetate template used for femoral planning can be inverted and used on the tibia.**

Step One: Position IM Alignment Guide

Use the universal handle to start a hole in the proximal tibia just anterior to the anterior cruciate ligament insertion and centered mediolaterally (Figure 104). This may seem too far anterior; however, it is the straight proximal extension of the tibial medullary canal. If a hole is started further posteriorly, excessive posterior slope may be cut into the proximal tibia.

Drill a hole using the 8 mm IM drill. Suction the canal to remove medullary contents.

Slowly insert the tibial IM rod (5977-44) into the canal. The flutes on the rod will aid decompression of the canal during insertion.

Attach either the 7° revision tibial boom (5787-10) or the 0° augment tibial boom (5125-60) to the rod (figure 105). **The selection of the boom will determine the posterior slope of the tibial resection.**



Figure 106



Figure 107

Step One: Position IM Alignment Guide (cont.)

Lower the adjustment knob on the IM alignment guide to the bottom of the threaded portion. Insert the 0° cut guide over the threaded portion of the alignment guide above the adjustment knob and slide it up until it just engages the dovetail (Figure 106). This will allow for final adjustment after the alignment guide has been secured in position. To hold the cut guide in place, advance the adjustment knob until it contacts the underside of the guide.

Only the 0° cut guide will fit onto the IM alignment guide. The 7° cut guide will not fit onto the IM alignment guide. Using the 0° cut guide with the 7° revision tibial boom will result in a 7° cut.

Slide the barrel of the IM alignment guide onto the boom, making sure that the locking knob has been adjusted to allow free access (Figure 107). Rotate the boom on the rod until the cut guide is properly positioned mediolaterally on the anterior tibia. Use the medial third of the tibial tubercle as a landmark. Then slightly secure the knob on the boom.



Figure 108



Figure 109

Step One: Position IM Alignment Guide (cont.)

To determine varus/valgus alignment, insert the extramedullary alignment arch onto the cut guide and insert the alignment rod with coupler through the arch, passing it distally toward the ankle (Figure 108). The distal end of the rod should point to the second toe.

If the surgeon would like to set the cut guide at a 90° angle to the tibial IM rod, tighten the knob at the top of the IM alignment guide **clockwise** in the 90° direction as etched on top of the knob (Figure 109). Do not overtighten the knob.

If the alignment check suggests a varus/valgus adjustment, rotate the barrel of the IM alignment guide on the boom to align the alignment rod to the second toe. When the appropriate varus/valgus alignment is achieved, tighten the knob at the top of the IM alignment guide **counterclockwise** in the “var-valg” direction as etched on top of the knob (Figure 110). This will hold the varus/valgus position of the cut guide. Do not overtighten the knob.



Figure 111



Figure 111a



Figure 111b



Figure 112



Figure 113

Step Two: Set Resection Level

Each tip of the tibial depth resection stylus indicates a different depth. The 2 mm tip is used to check the depth from the defective tibial condyle for a minimal cut. The 10 mm tip is used to check the depth from the least involved tibial condyle for an anatomic cut.

Insert the tibial depth resection stylus into the top of the cut guide, using the hole that corresponds to the defective tibial condyle (Figure 111). The stylus will snap into the hole (Figures 111a and 111b). Confirm that it is fully seated and properly oriented. The 2 mm tip should rest on the tibial condyle (Figure 112). This positions the slot of the cut guide to remove 2 mm of bone below the tip of the stylus.

Alternatively, rest the 10 mm tip of the stylus on the cartilage of the least involved condyle (Figure 113). This will allow the removal of the same amount of bone that the thinnest tibial component would replace.

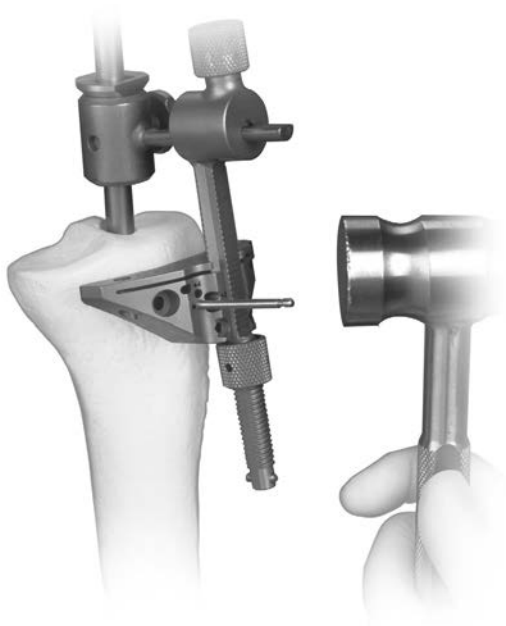

Figure 114



Figure 115

Step Two: Set Resection Level (cont.)

These two points of resection will usually not coincide. The surgeon must determine the appropriate resection based on patient age, bone quality, and the type of prosthetic fixation planned.

Adjust the cut guide to the desired depth by turning the adjustment knob. Then insert 75 mm headless holding pins into the holes marked “0” (Figure 114). Alternatively, rest the 10 mm tip of the stylus on the cartilage of the least involved condyle (Figure 113). This will allow the removal of the same amount of bone that the thinnest tibial component would replace.

Step Three: Resect the Proximal Tibia

Loosen the adjustment knob below the cut guide until the knob is at the bottom of the threaded portion of the rod. Loosen the varus/valgus adjustment knob on the IM alignment guide. Use a slaphammer to raise the IM rod until the dovetail portion of the IM alignment guide disengages from the cut guide. Remove the alignment assembly, leaving the cut guide in place on the bone.

If desired, the alignment arch and alignment rod with coupler can be used on the cut guide again to check alignment.

Additional 2 mm adjustments may be made by using the sets of holes marked -2, +2, and +4. The markings on the cut guide indicate, in millimeters, the amount of bone resection each will yield relative to the standard tibial resection set by the cut guide and tibial depth resection stylus. Once the tibial resection has been determined, use the hex-head holding pins or silver spring pins to further stabilize the guide.

Use a 0.050-Inch/1.27 mm oscillating saw blade through the slot on the cut guide to cut the proximal surface of the tibia flat (Figure 115). Then remove the cut guide.



Figure 116

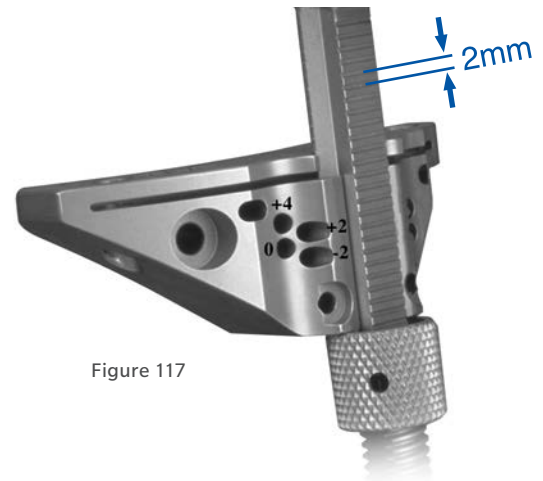

Figure 117

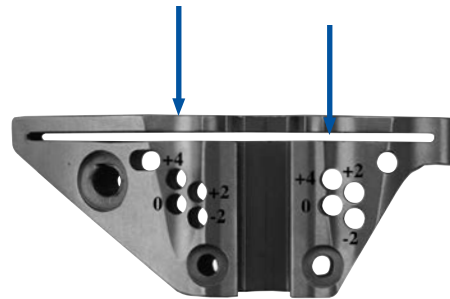

Figure 118

Step Three: Resect the Proximal Tibia (cont.)

Optional Technique

If desired, the cut can be made from the top surface of the cut guide. The top surface of the guide is 4 mm above the slot (Figure 116), so the position of the guide must be adjusted to account for this difference. The adjustment can be made when the cut guide is first positioned by using the etch lines, which are in 2 mm increments, on the IM alignment guide (Figure 117).

Alternatively, the adjustment can be made after the IM alignment guide is removed by lifting the cut guide off the headless pins, which were inserted through the holes marked “0,” and reinserting the guide through the holes marked “+4” (Figure 118). Proceed to “Finish the Tibia” on page 59.

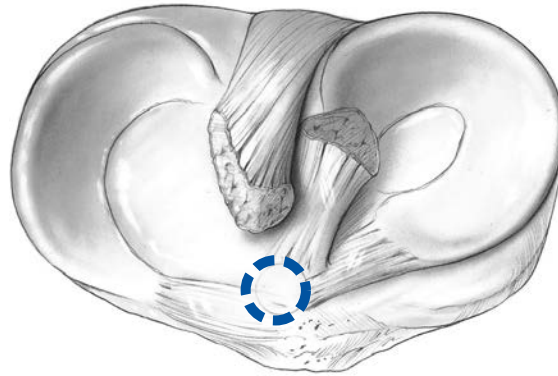

Figure 119

Spike Arm Intramedullary Technique

To improve exposure of the tibial surface, use the tibial retractor to lever the tibia anteriorly. This instrument should be carefully positioned against the posterior cortex of the tibia subperiosteally to prevent neurovascular injury. Use the patella tendon retractor to retract the patella laterally.

A preoperative radiograph of the tibia is necessary to make sure that the tibial shaft is straight and will accept the tibial IM rod. Some tibias are bowed or have too small a canal and will not accept the rod. The acetate template used for femoral planning can be inverted and used on the tibia.

Step One: Insert Im Rod

Use the universal handle to start a hole in the proximal tibia just anterior to the anterior cruciate ligament insertion and centered mediolaterally (Figure 119). This may seem too far anterior; however, it is the straight proximal extension of the tibial medullary canal. If a hole is started further posteriorly, excessive posterior slope may be cut into the proximal tibia.

Drill a hole using the 8 mm IM drill. Suction the canal to remove medullary contents.

Slowly insert the tibial IM rod (5977-44) into the canal. The flutes on the rod will aid decompression of the canal during insertion.

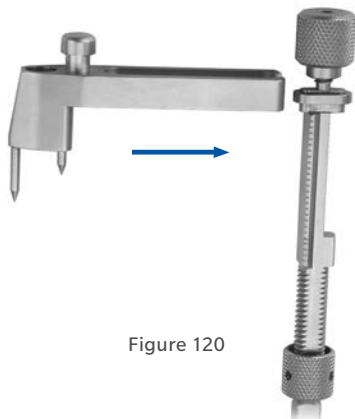

Figure 120



Figure 121



Figure 122



Figure 122a



Figure 122b

Step Two: Position Cut Guide

The system includes four different cut guides: a 7° guide and a 0° guide, both in left and right configurations.

Slide the spike arm onto the top of the spike arm telescoping rod and secure it temporarily by turning the knob at the top of the rod (Figure 120).

Lower the adjustment knob in the middle of the spike arm telescoping rod to the bottom of the threaded portion. Insert the cut guide over the threaded portion of the rod above the adjustment knob and slide it all the way up on the dovetail (Figure 121). To hold the cut guide in place, advance the adjustment knob to the end of its range of travel. This will allow for final adjustment after the alignment assembly has been secured in position.

Slide the spike arm assembly over the IM rod (Figures 122, 122a and 122b). Lower the assembly until the long spike engages the tibial surface. Adjust the assembly to the correct rotation. Impact the spike arm until both the long and short spikes are fully engaged in bone. Loosen the knob at the top of the spike arm telescoping rod, and slide the rod and cut guide toward the anterior tibial surface. Then tighten the knob.

To confirm alignment, insert the extramedullary alignment arch onto the cut guide and insert the alignment rod with coupler through the arch, passing it distally toward the ankle. The distal end of the rod should point to the second toe.



Figure 123



Figure 123a



Figure 123b

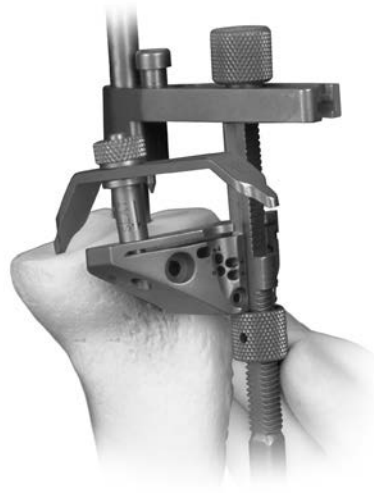

Figure 124



Figure 125

Step Three: Set Resection Level

Each tip of the tibial depth resection stylus indicates a different depth. The 2 mm tip is used to check the depth from the defective tibial condyle for a minimal cut. The 10 mm tip is used to check the depth from the least involved tibial condyle for an anatomic cut.

Insert the tibial depth resection stylus into the top of the cut guide, using the hole that corresponds to the defective tibial condyle (Figure 123). The stylus will snap into the hole (Figures 123a and 123b). Confirm that it is fully seated and properly oriented.

The 2 mm tip should rest on the tibial condyle (Figure 124). This positions the slot of the cut guide to remove 2 mm of bone below the tip of the stylus.

Alternatively, rest the 10 mm tip of the stylus on the cartilage of the least involved condyle (Figure 125). This will allow the removal of the same amount of bone that the thinnest tibial component would replace.

These two points of resection will usually not coincide. **The surgeon must determine the appropriate resection based on patient age, bone quality, and the type of prosthetic fixation planned.**

Adjust the cut guide to the desired depth by turning the adjustment knob. Then insert 75 mm headless holding pins into the holes marked "0".



Figure 126

Step Four: Resect the Proximal Tibia

Loosen the adjustment knob below the cut guide until the knob is at the bottom of the threaded portion of the rod. Use a slaphammer to raise the tibial im rod and spike arm assembly until the dovetail portion of the IM alignment guide disengages from the cut guide. Remove the alignment assembly, leaving the cut guide in place on the bone.

If desired, the alignment arch and alignment rod with coupler can be used on the cut guide again to check alignment.

Additional 2 mm adjustments may be made by using the sets of holes marked -2, +2, and +4. The markings on the cut guide indicate, in millimeters, the amount of bone resection each will yield relative to the standard tibial resection set by the cut guide and tibial depth resection stylus. Once the tibial resection has been determined, use the hex-head holding pins or silver spring pins to further stabilize the guide.

Use a 0.050-Inch/1.27 mm oscillating saw blade through the slot on the cut guide to cut the proximal surface of the tibia flat (Figure 126). Then remove the cut guide.



Figure 127

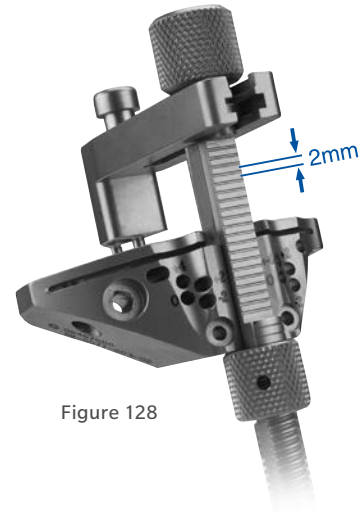

Figure 128

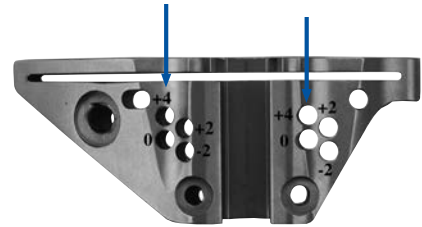

Figure 129

Step Four: Resect the Proximal Tibia (cont.)

Optional Technique

If desired, the cut can be made from the top surface of the cut guide. The top surface of the guide is 4 mm above the slot (Figure 127), so the position of the guide must be adjusted to account for this difference. The adjustment can be made when the cut guide is first positioned by using the etch lines, which are in 2 mm increments, on the spike arm telescoping rod (Figure 128).

Alternatively, the adjustment can be made after the alignment assembly is removed by lifting the cut guide off the headless pins, which were inserted through the holes marked “0,” and reinserting the guide through the holes marked “+4” (Figure 129). Proceed to “Finish the Tibia” on page 59.

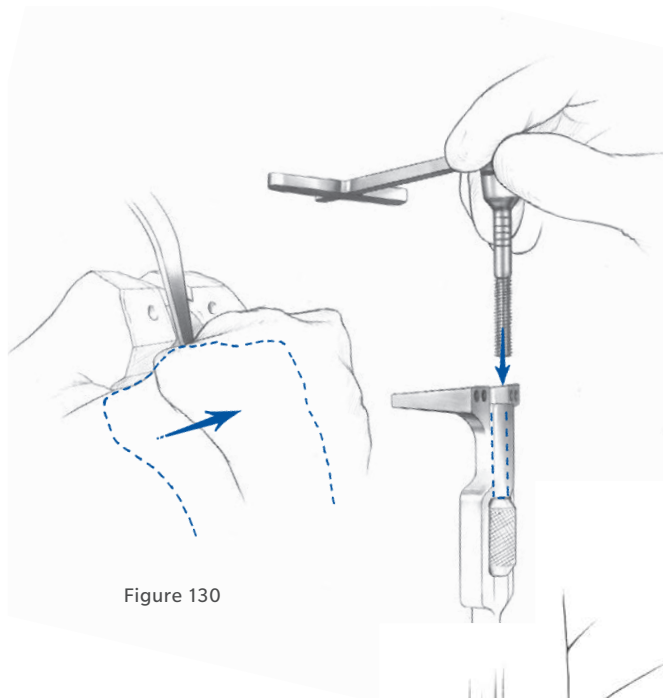

Figure 130

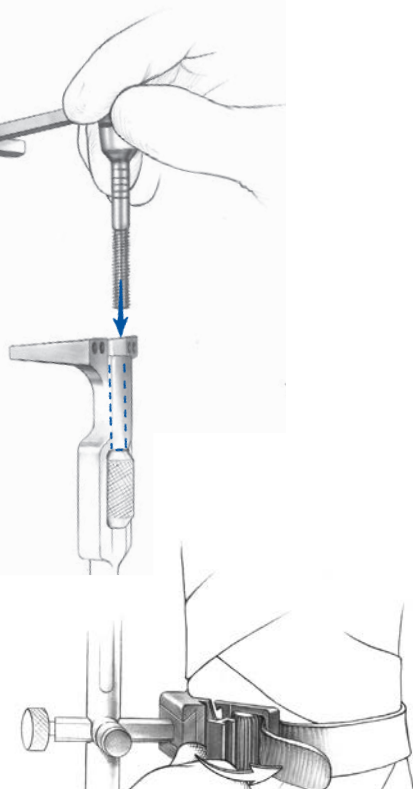

Figure 131

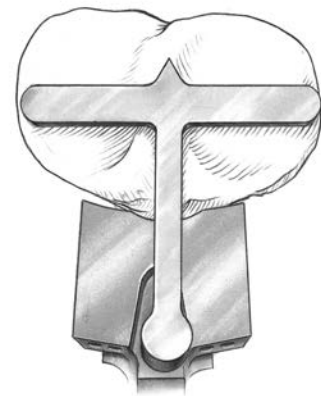

Figure 132

Micro-Mill/5-in-1 Instrumentation

Step One: Align the Tibia

In this step, the tibial cut is aligned, ensuring proper posterior slope and rotation, and that the resection is perpendicular to the mechanical axis.

Retract the tibia anteriorly by using the tibial retractor (Figure 130). Adjust the length of the extramedullary tibial alignment guide to fit the patient's tibia. Attach the proximal tibial reference guide to the proximal end of the guide (Figure 131). Do not fully seat the reference arm, leave 1-2 lines visible.

Center the foot of the guide at the ankle and tighten the ankle strap (Figure 132). The true center of the ankle is about 5 mm-10 mm medial to the midpoint between the subcutaneous palpable medial and lateral malleoli. Position the proximal portion superior to the tibial tubercle and center

it mediolaterally. This will normally be the medial third of the tibial tubercle. Use the resection guide in the depth resection slot on the reference guide to ensure that the proximal portion is not positioned too far superiorly. This will show the maximum tibial resection when the tibial milling base is inserted to the same depth as the reference guide. If there is not enough resection possible, move the alignment guide distally. Also observe the proximal tibial reference guide to help ensure that proper rotation has been achieved (Figure 133).

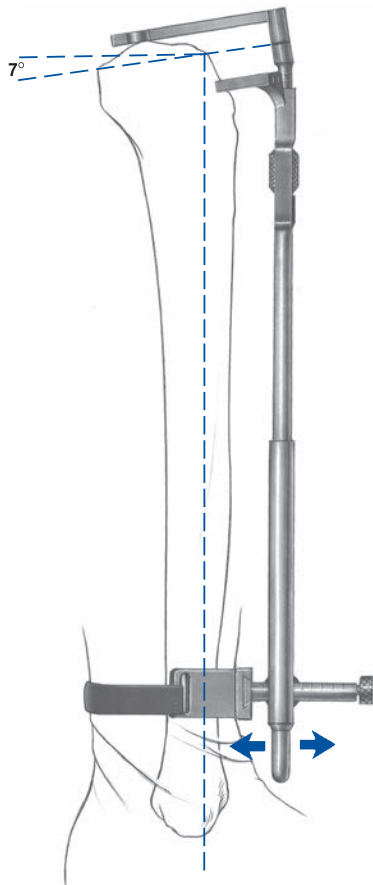

Figure 133

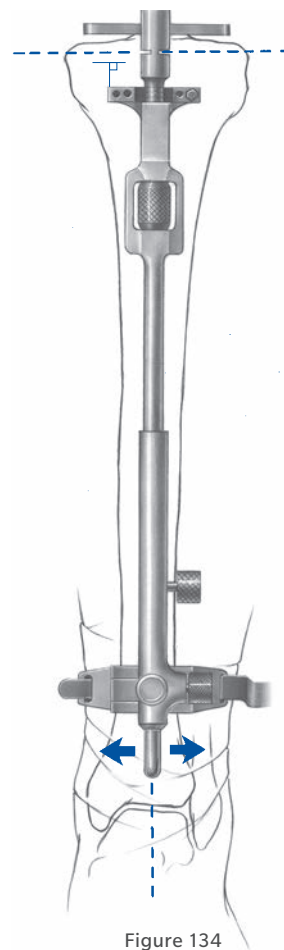

Figure 134

Step One: Align the Tibia (cont.)

Ensure that the guide is parallel to the mechanical axis in the sagittal plane. If it is not, adjust the guide in or out at the ankle until it is parallel (Figure 133). Observe the proximal tibial reference guide to help confirm the 7° posterior slope and rotation. When the position is set, pin the guide with one pin on the lateral side. Adjust the distal ankle portion in the mediolateral plane so the guide follows the anterior tibial crest (Figure 134).

This will ensure that the resected surface will be 90° to the mechanical axis. Observe the proximal tibial reference guide to help confirm that the resection will have the appropriate varus/valgus angle. If alignment is correct, insert a second pin.

Remove the proximal tibial reference guide.

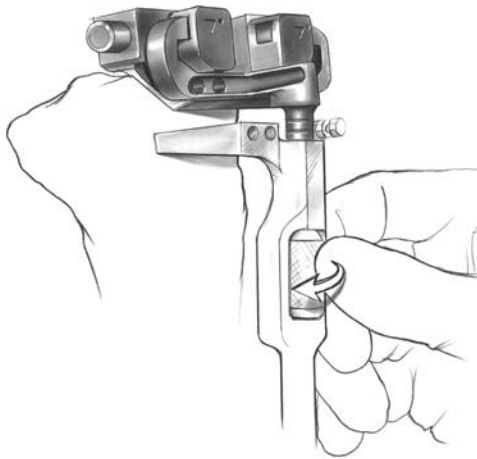

Figure 135

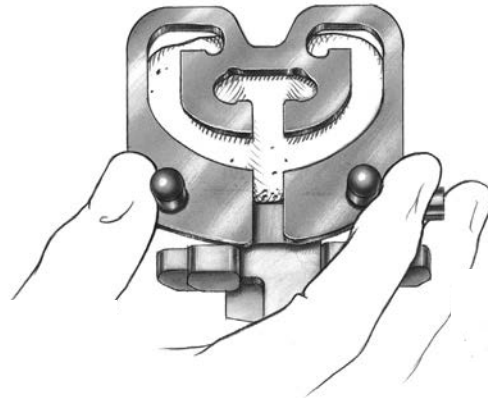

Figure 136

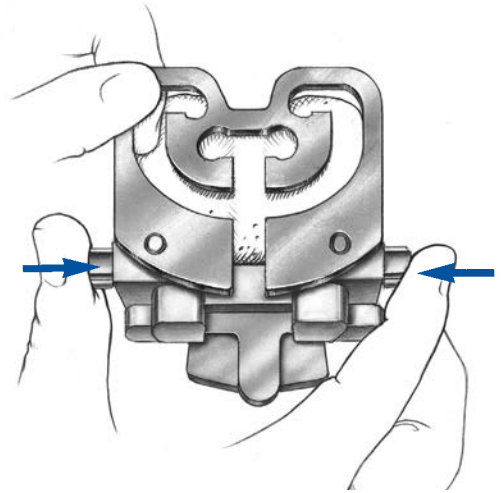

Figure 137

In the next step, resect the tibia, the milling or 5-in-1 techniques can be used. First, the milling technique will be shown and then the 5-in-1 technique. To proceed directly to 5-in-1 technique go to page 57.

Step Two (Milling): Resect the Tibia

Attach the tibial milling base to the tibial alignment guide by placing it into the guide and engaging the threads by turning the adjustment knob (Figure 135). Choose the appropriate tibial milling template by placing them one at a time over the tibia until one provides the desired tibial coverage for bone removal (Figure 136). This does not dictate

the final size selection for the tibial base plate. The outer edge of the template corresponds to the cutting edge of the mill. Attach the selected template to the tibial milling base by compressing the two plungers on each side of the base (Figure 137). If the template contacts the femur, flex the knee further and retract the tibia more anteriorly. In very tight knees, it may not be possible to mill the tibia and the saw blade technique should be used.

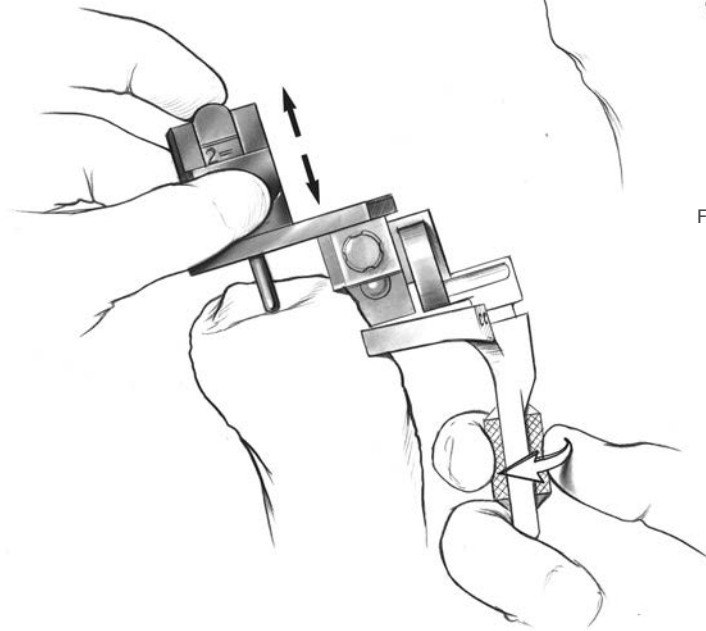

Figure 138

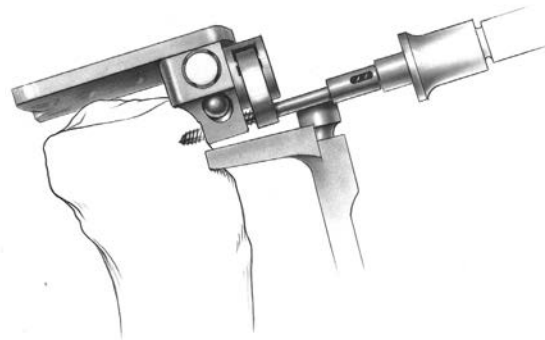

Figure 139

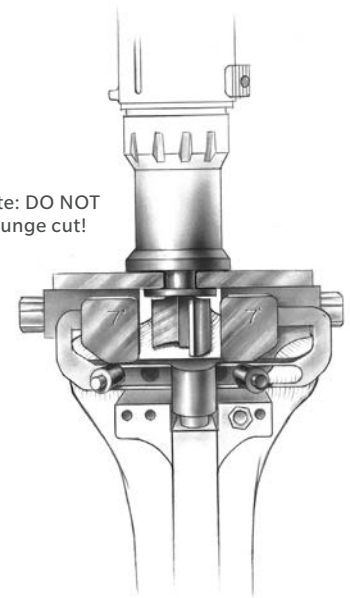

Figure 140

Step Two (Milling): Resect the Tibia (cont.)

Place the tibial milling depth resection gauge onto the template. Adjust the tibial milling base to the proper level (Figure 138). Keep a finger on the plunger to ensure that the probe stays in contact with bone. The gauge should read 10 mm on the intact condyle for an anatomic cut, or 2 mm on the defective condyle for a minimal cut. These two points of resection will usually not coincide. The surgeon must decide between an anatomic and minimal resection based on patient age, bone quality, and type of prosthetic implant planned. After the depth is set, move the template mediolaterally until it is centered over the PCL attachment site. When positioned properly, use the drill/reamer to pin the tibial milling base in place with two tibial long-threaded spring pins (Figure 139).

Check to ensure that all soft tissue is retracted from under the template and that there is adequate clearance of the posterior femoral condyles. The patella tendon retractor can be used to assist. With the milling drape over the assembled mill and the operative sight, retract the shield and engage the mill into the anterior opening of the template (Figure 140).

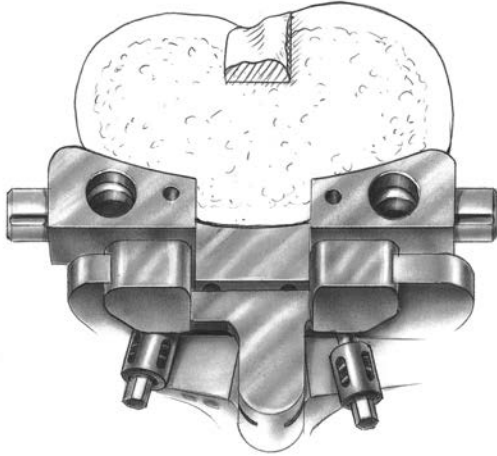

Figure 141

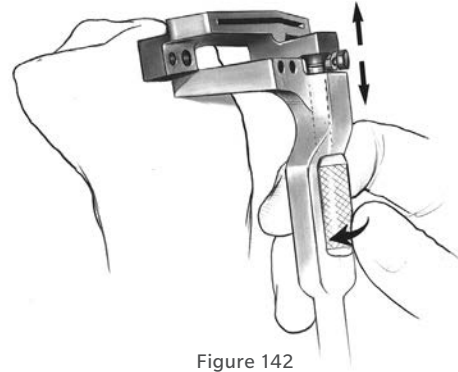

Figure 142

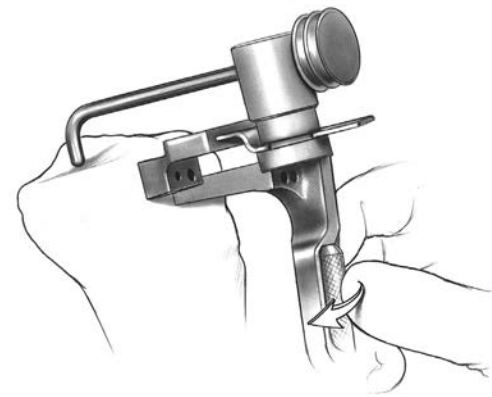

Figure 143

Step Two (Milling): Resect the Tibia (cont.)

Disengage the safety and start the mill with the cutter slightly off the bone. Mill the tibia by following the tracks on the template in a clockwise direction. Keep the mill against the outside edge of the track. Depending on the level of resection, the template may contact the tibial crest and prevent milling. If this occurs, the crest should be removed with a rongeur or oscillating saw to allow the mill to cut properly.

When milling is complete, turn off and remove the mill. Pull the shield back over the cutter. Remove the tibial milling template and check the proximal tibial surface resection (Figure 141). If bone remains around the edges of the proximal tibia, attach the next larger template and remill. If osteophytes are present, remove them with a rongeur. When complete, remove the tibial milling template and tibial milling base.

Proceed to “Finish the Tibia” on page 59.

Step Two (5-IN-1): Resect the Tibia

Insert the tibial cutting head into the tibial alignment guide (Figure 142). Insert the 10 mm tab of the tibial depth resection gauge into the cutting slot of the tibial cutting head and adjust the platform until the arm of the gauge rests on the cartilage of good condyle (Figure 143).

ⓘ **Note:** IM tibial resection instrumentation and IM tibial milling instrumentation are also available for tibial saw blade technique.

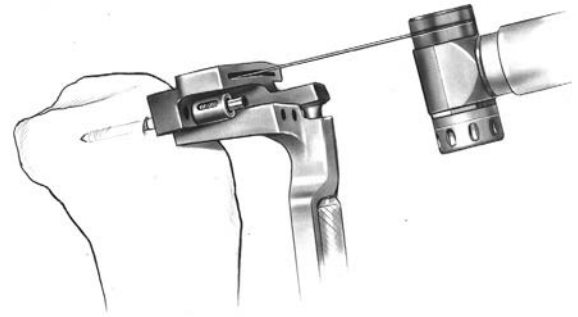

Figure 145

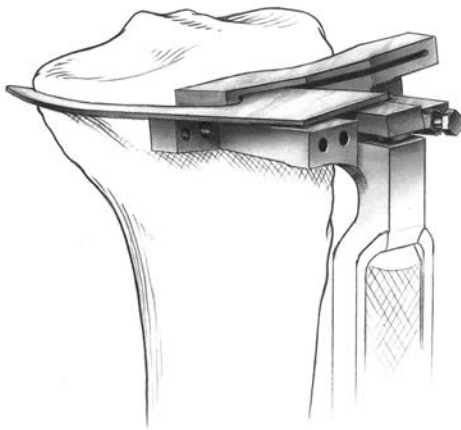

Figure 144

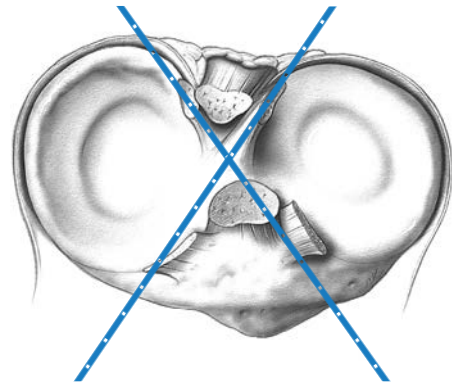

Figure 146

Step Two (5-IN-1): Resect the Tibia (cont.)

Be sure that the mark on the arm of the gauge is lined up with the mark on the base of the gauge. This will ensure that the arm is properly rotated within its base and that the proper resection depth is made. This positions the cutting slot to remove the same amount of bone that the thinnest tibial component would replace to give an anatomic fit. The resection guide can also be used to visualize where the cut will exit the posterior tibia (Figure 144).

Optionally, the 2 mm tab can be placed into the cutting slot. The arm of the gauge should rest on the defective condyle to be resected. This will allow the removal of two millimeters of bone below the tip of the gauge and provide a minimal resection. These 2 mm and 10 mm points of resection will usually not coincide. **The surgeon must decide between an anatomic and minimal resection based on patient age, bone quality, and the type of prosthetic implant planned.**

Remove the depth gauge and secure the tibial cutting head with two silver spring pins using the female hex driver. Do not use gold-sleeved pins. (Two standard 1/8-inch pins can also be used to secure the guide). Use the appropriate thickness blade (0.050-Inch/1.27 mm) and an oscillating saw to cut the proximal tibia, taking care not to resect the cruciate island (Figure 145). A reciprocating saw can be used to aid in resecting around the cruciate island (Figure 146).

Optional Spacer Alignment Technique

Once the tibia and femur are resected, the spacer/alignment guides can be used to check that the flexion and extension gaps are equal.

Proceed to “Finish the Tibia” on page 59.

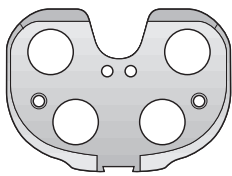

Pegged Tibial
Sizing Plate

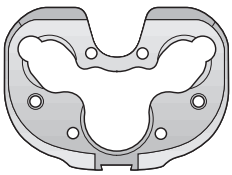

Stemmed Tibial
Sizing Plate

Figure 147

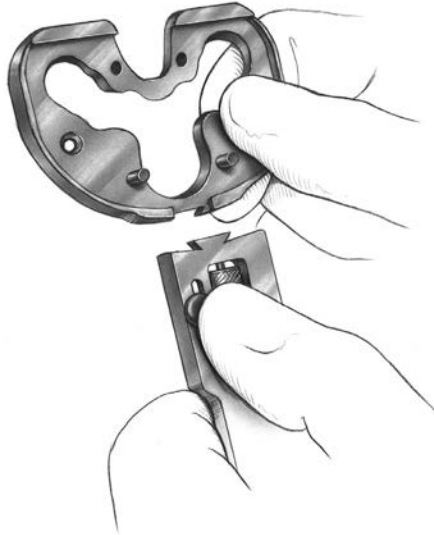

Figure 148

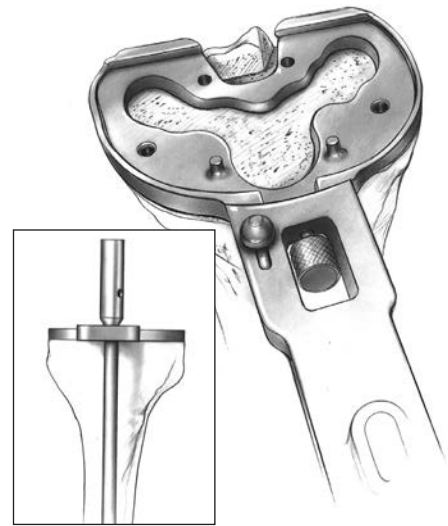

Figure 149

Finish the Tibia

The tibia can be finished prior to trial reduction if the implant position will be chosen based on anatomic landmarks. Alternatively, the provisionals, in combination with the sizing plate, can be used to perform a trial range of motion to aid in tibial location.

Position Based on Anatomic Landmarks

Select the proper style of tibial sizing plate (for either stemmed or pegged tibias) and the plate size that provides the desired tibial coverage (Figure 147).

The selected color code designation on the tibial sizing plate should be compared to the color code designations on the anterior flange of the selected femoral provisional. At least one of the colors and size designation listed on the femoral Provisional must match at least one color on the tibial sizing plate and the bearing to ensure that the components will be kinematically matched. The

colors and sizes must match exactly. For example, Yellow A/B = Yellow A/B. The striped colors are not the same as the standard colors (Yellow A/B \neq Striped Yellow A/B) and should not be viewed as a match. If there is no match between the femoral provisional and tibial sizing plate, adjust the size of the sizing plate being used to yield a match.

Attach the tibial provisional/drill guide holding clamp to the selected tibial sizing plate by depressing the button on the holding clamp and engaging the dovetail on the holding clamp with the dovetail on the sizing plate and secure by tightening the thumb screw (Figure 148).

Generally, the holding clamp aligns with the anterior aspect of the tibia. Rotate the sizing plate so the holding clamp points at, or slightly medial to, the tibial tubercle (Figure 149). The alignment rod can be used to help confirm varus/valgus alignment.

Pin the sizing plate in place with two short-head holding pins.

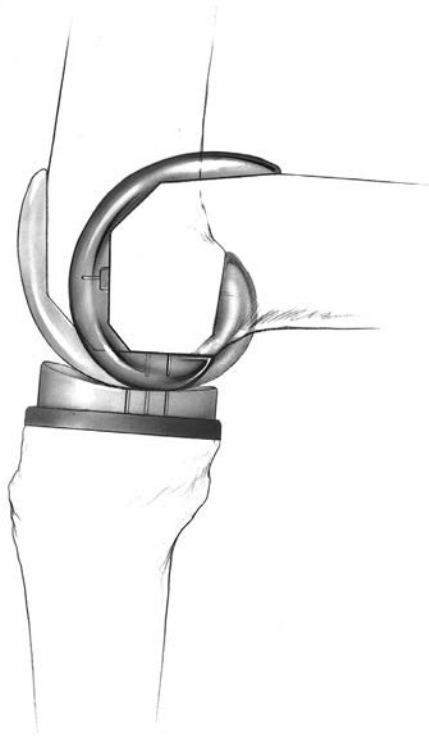

Figure 150



Figure 151

Position Based on Trial Range of Motion

If using the provisionals and performing a range of motion to determine tibial component placement, the patella preparation should be completed. Then select the proper size and style of tibial sizing plate. Ensure that the plate chosen provides the desired tibial coverage. Again, a color match with the femoral provisional must occur for a proper kinematic match.

Insert the proper femoral provisional, patellar provisional, tibial sizing plate, and bearing provisional. Select the color and letter designation of bearing provisional that is the same as the color match chosen for the femoral provisional and sizing plate. Ensure soft tissue balance is appropriate.

Flex and extend the knee with the provisionals in place. With proper soft tissue balancing complete, the tibial component tends to seat itself in the position where it best articulates with the femur (Figure 150).

Note: During the trial reduction, observe the relative position of the femoral provisional on the bearing provisional by using the lines on both provisionals. The lines can be used to determine if posterior rollback is occurring, whether the PCL is functional, and if the femoral component will contact the tibial bearing in the proper location. If the PCL is properly balanced, the femoral provisional should sit near the anterior or center lines on the bearing provisional in extension and near the posterior line in flexion.

If the femoral provisional sits posterior to the lines, the PCL may be too tight or the bearing may be too thick. If the femoral provisional sits anterior to the lines, the PCL may be too loose.

After this self-centering process has occurred, mark the position of the component with methylene blue or electrocautery (Figure 151).

Remove the bearing provisional and pin the sizing plate in place with two short-head holding pins. Ensure that the sizing plate remains in the proper position when pinning.



Figure 152

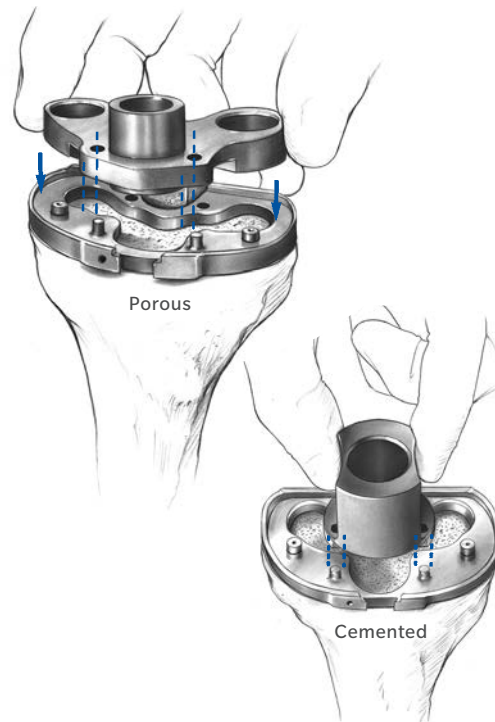

Figure 153

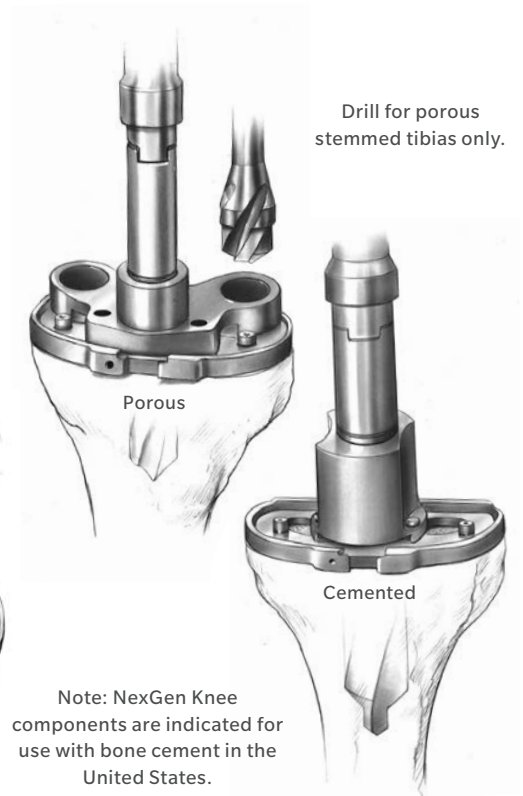

Figure 154

Pegged Tibial Plate Preparation (For Use With NexGen CR Components Only)

With the tibial sizing plate pinned in position, take the tibial peg drill and drill the four peg holes. After drilling each hole, place a tibial holding peg in each to aid in stability (Figure 152).

If trial reduction has been completed, remove the sizing plate and other provisionals. If it has not been completed, proceed to “Trial Reduction and Implantation” on page 72.

Stemmed Tibial Plate Preparation

Once the tibial sizing plate is pinned in position, place the appropriate size porous or cemented stem drill guide on the sizing plate and drill for the stem with the porous or cemented stem drill (Figure 153). Drill until the engraved line on the drill is in line with the top of the drill sleeve (Figure 154). If one is using a porous stemmed tibial plate, drill for the posterior pegs with the tibial peg drill. Remove the drill and drill guide.

ⓘ **Note:** When cementing the stemmed tibia, (precoat or porous), you must use the cemented stem drill guide and cemented stem drill to allow for optimal cement fixation.

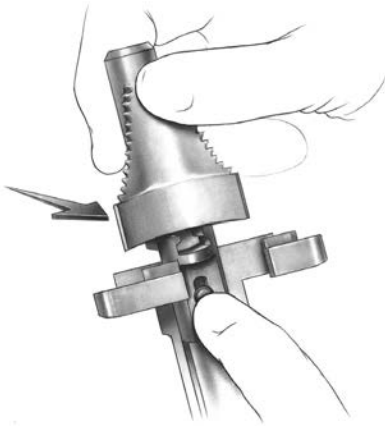

Figure 155

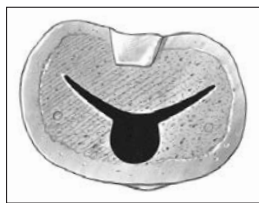

Figure 156



Figure 157

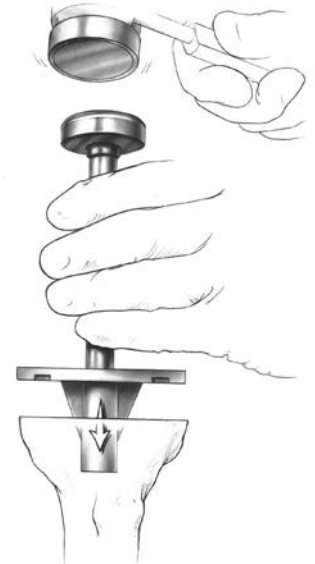

Figure 158

Finish the Tibia (cont.)

Assemble the proper size tibial broach to the broach impactor (Figure 155). The broach can only be assembled from the front. Seat the impactor on the tibial sizing plate and impact the broach to the proper depth indicated by the etched groove on the shaft aligning with the impactor handle. The broach has a built-in stop so it cannot be overimpacted (Figure 156).

Remove the broach assembly and sizing plate. Use the correct size stemmed tibial provisional to ensure proper fit before implanting the final components. Assemble the impactor onto the provisional until completely seated. Impact the stemmed tibial provisional (Figures 157 and 158).

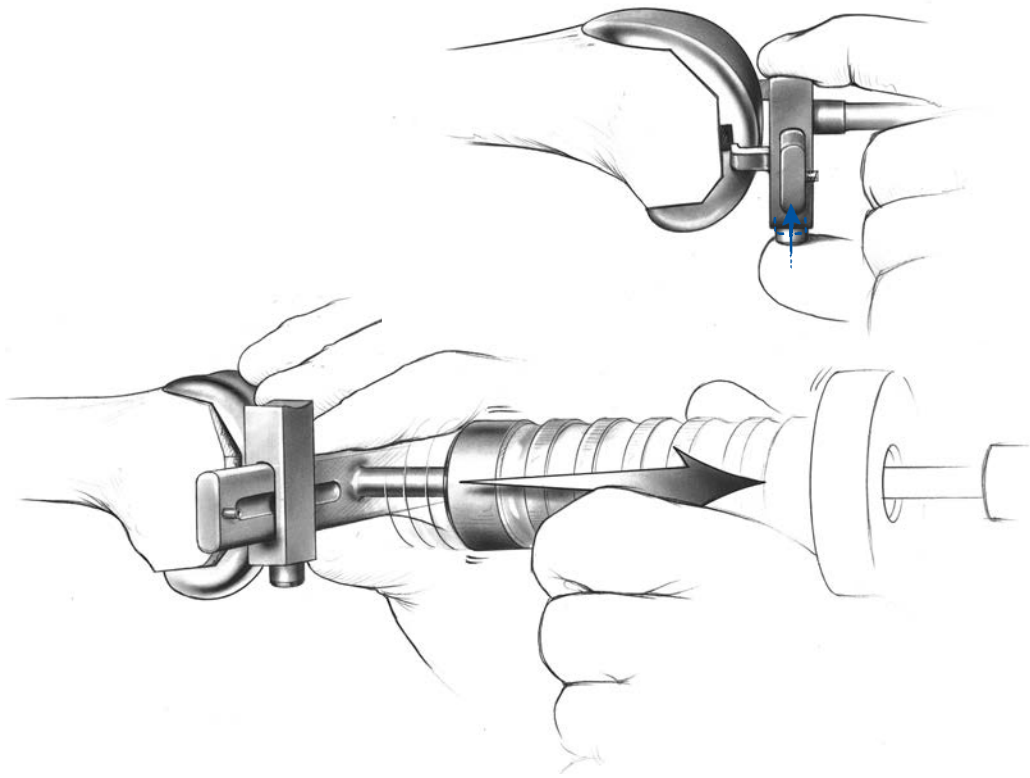

Figure 159

Finish the Tibia (cont.)

Once trial reduction is complete, assemble the femoral extractor to the femoral provisional and remove the trial. The slaphammer extractor can be used to remove the component, if needed (Figure 159).

Patellar Preparation

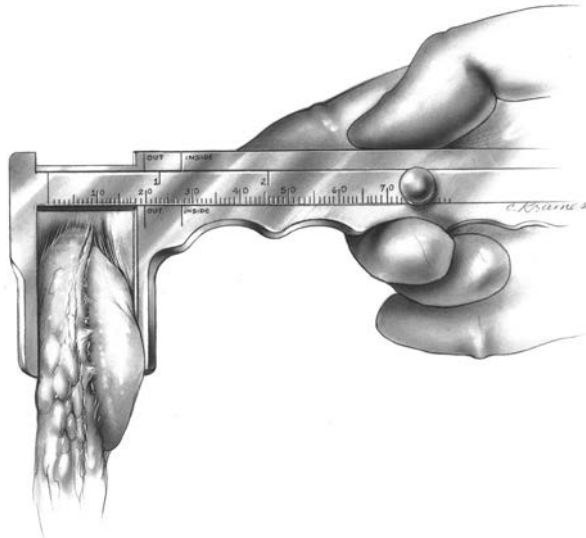

Figure 160

Prepare the Patella

Sharply dissect through the prepatellar bursa to expose the anterior surface of the patella. This will provide exposure for affixing the anterior surface into the patellar clamp.

Remove all osteophytes and synovial insertions from around the patella. Be careful not to damage tendon insertions on the bone. Use the patellar caliper to measure the thickness of the patella (Figure 160). Subtract the implant thickness from the patella thickness to determine the amount of bone that should remain after resection.

Patella Thickness - Implant Thickness = Bone Remaining

	Implant Thicknesses	
	Micro	Standard
26 mm	7.5 mm	—
29 mm	7.5 mm	8.0 mm
32 mm	8.0 mm	8.5 mm
35 mm	8.0 mm	9.0 mm
38 mm	—	9.5 mm
41 mm	—	10.0 mm

Note: At least 11 mm of total bone will remain to allow for implant pegs if the patella reamer is used.

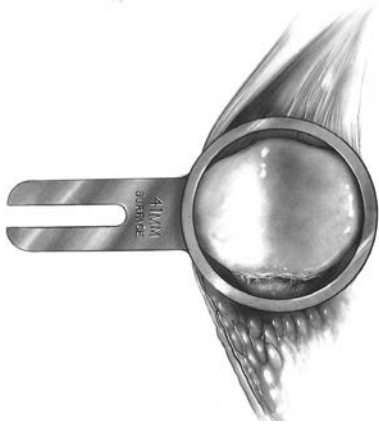

Figure 161

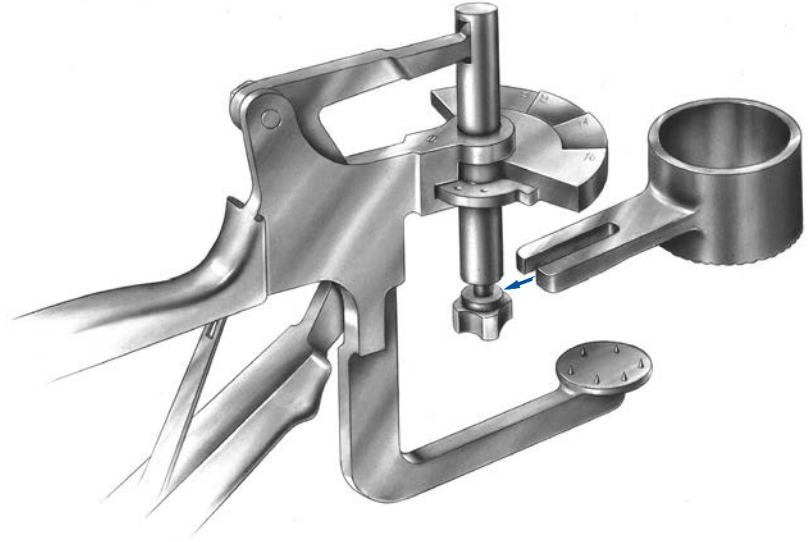

Figure 162

Resect the Patella

Patella Reamer Technique Total Surfacing Procedure

Use the patella reamer surfacing guides as templates to determine the appropriate size guide and reamer. Choose the guide which fits snugly around the patella, using the smallest guide possible (Figure 161). If the patella is only slightly larger than the surfacing guide in the mediolateral dimension, use a rongeur to remove the medial or lateral edge until the bone fits the guide. Insert the appropriate size patella reamer surfacing guide into the patella reamer clamp (Figure 162). Turn the locking screw until tight.

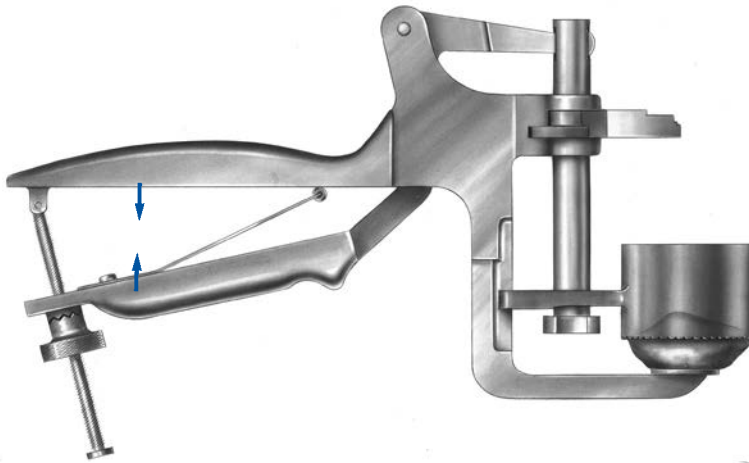

Figure 163

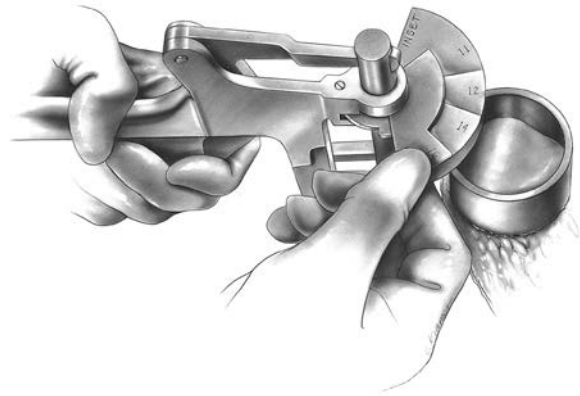

Figure 164

Patella Reamer Technique Total Surfacing Procedure (cont.)

Apply the patella reamer clamp at a 90° angle to the longitudinal axis with the patella reamer surfacing guide encompassing the bearing of the patella. Squeeze the clamp until the anterior surface of the patella is fully seated against the fixation plate (Figure 163).

ⓘ Note: Patella reamers that use the pilot drill can also be used.

Turn the clamp screw to hold the instrument in place. The anterior surface must fully seat upon the pins and contact the fixation plate.

Turn the depth gauge wing on the patella reamer clamp to the proper indication for the correct amount of bone that is to remain after reaming (Figure 164).

Attach the appropriate size patella reamer blade

to the appropriate size patella reamer shaft. Use only moderate hand pressure to tighten the blade. Remove the medial or lateral edge until the bone fits the guide. Insert the appropriate size patella reamer surfacing guide into the patella reamer clamp (Figure 162). Turn the locking screw until tight.

Do not overtighten the blade. Insert the patella reamer shaft into a drill/reamer. Insert the reamer assembly into the patella reamer surfacing guide. Raise the reamer slightly off the bone and bring it up to full speed. Advance it slowly until the prominent high points are reamed off the bone. Continue reaming with moderate pressure until the step on the reamer shaft bottoms out on the depth gauge wing of the patella reamer clamp. Remove the reamer clamp assembly.

Proceed to Finish the Patella on page 68.

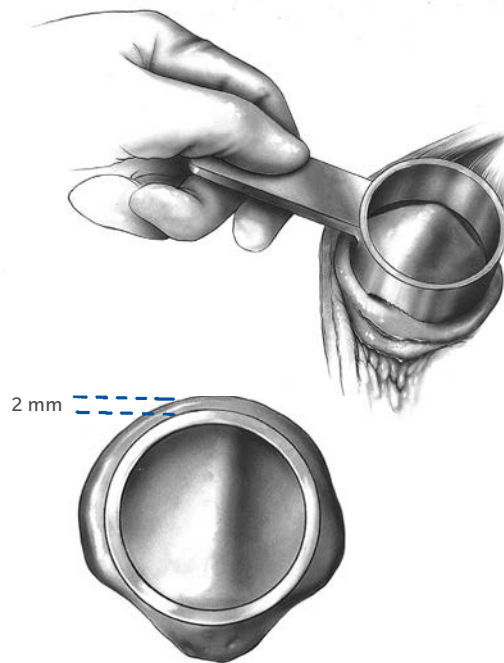

Figure 165

Insetting Technique

Use the patella reamer inseting guides as templates to determine the appropriate size guide and reamer. Choose the guide which will allow approximately 2 mm between the superior edge of the patella and the outer diameter of the guide (Figure 165).

Insert the appropriate size patella reamer inseting guide into the patella reamer clamp. Turn the locking screw until tight. Apply the patella reamer clamp at a 90° angle to the longitudinal axis with the patella reamer inseting guide on the bearing. Squeeze the clamp until the anterior surface of the patella is fully seated against the fixation plate. Turn the clamp screw to hold the instrument in place. The anterior surface must fully seat on the pins and contact the fixation plate.

Turn the clamp wing to the “inset” position.

Attach the appropriate size patella reamer blade to the appropriate size patella reamer shaft. Use only moderate hand pressure to tighten the blade.

Do not overtighten the blade. Insert the patella reamer reamer shaft into a drill/reamer.

ⓘ Note: Patella reamers that use the pilot drill can also be used.

Use the patella reamer depth stops to control the amount of bone to be removed based on the thickness of the implant chosen.

(Note: if using a primary porous patella with Trabecular Metal™ Material, all implants are 10 mm thick). The depth gauge wing on the patella reamer clamp can be used instead of the stops to control the amount of bone remaining, rather than the amount of bone removed.

Insert the reamer assembly into the patella reamer inseting guide. Raise the reamer slightly off the bone and bring it up to full speed. Advance it slowly until the prominent high points are reamed off the bone. Continue reaming with moderate pressure. Remove the reamer clamp assembly. Proceed to Finish the Patella on page 68.

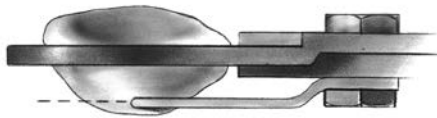

Figure 166

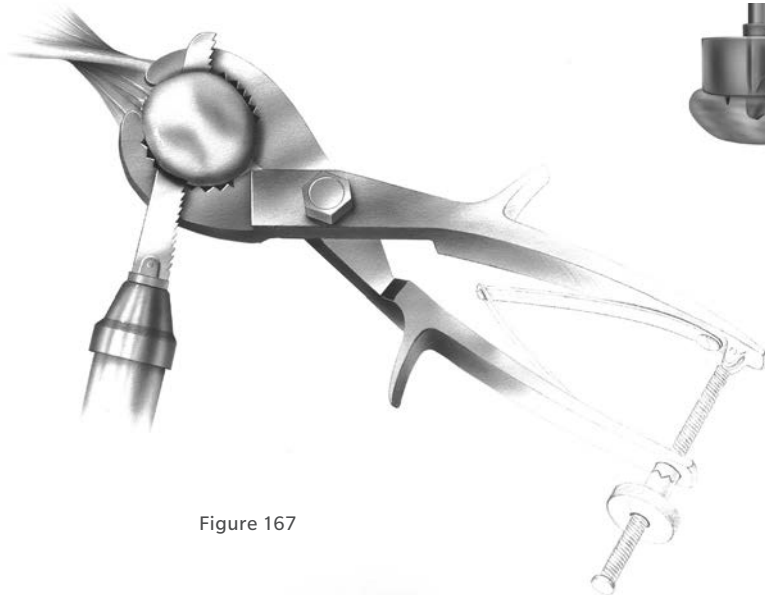

Figure 167



Figure 168

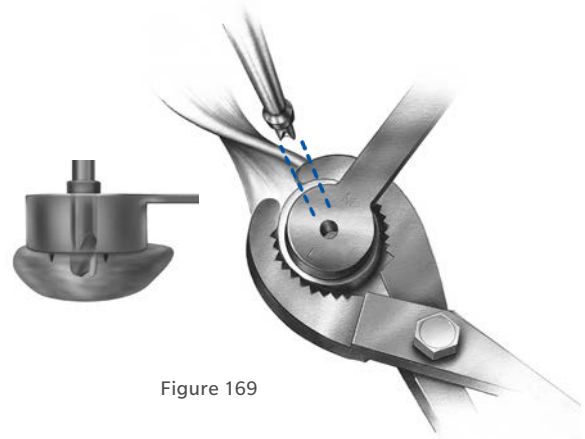

Figure 169

Universal Saw Guide Technique

Apply the universal patella saw guide in line with the patellar tendon. Push the patella up between the jaws of the saw guide. Level the patella within the saw guide jaws and use the thumb screw to tighten the guide.

The amount to be resected across the top of the saw guide jaws should be approximately the same on all sides. Check to be sure that the 10 mm gauge does not rotate beneath the anterior surface of the patella. If the gauge hits the anterior surface of the patella as it is rotated, this indicates that at least 10 mm of bone stock will remain after the cut (Figure 166).

Cut the patella flat so that a smooth surface remains (Figure 167).

Finish the Patella

NexGen Primary Porous Patella with Trabecular Metal Material

Center the appropriate patella drill guide over the resected patella surface with the handle on the medial side of the patella and perpendicular to the tendon. Press the drill guide firmly in place so that the teeth fully engage and the drill guide sits flat on the bone surface (Figure 168). Drill the peg hole making sure the drill stop collar contacts the top of the drill guide (Figure 169).

Note: The primary porous patellar clamp may be used to fully seat the drill guide on hard sclerotic bone surfaces.

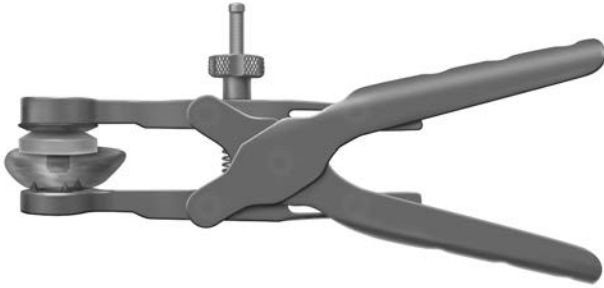

Figure 170

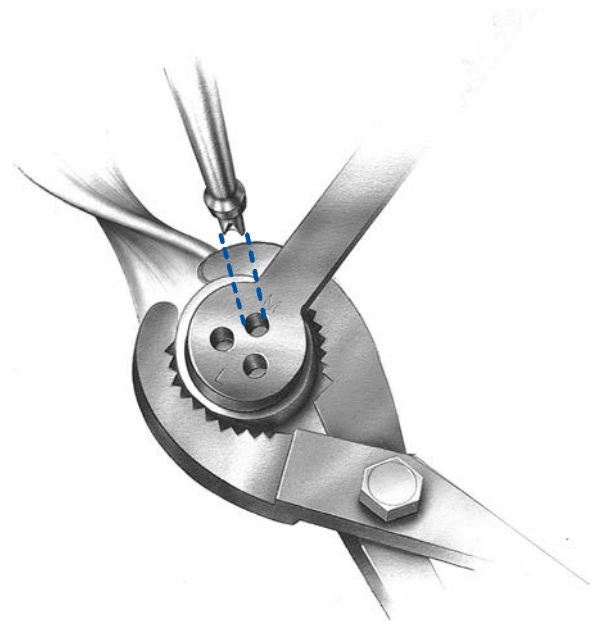

Figure 171

NexGen Primary Porous Patella with Trabecular Metal Material (cont.)

Apply cement to the Trabecular Metal Material and post while in a doughy consistency. Locate the drilled post hole and use the primary porous patellar clamp to insert and secure the patella in place. Fully open the jaws of the clamp and align the teeth to the anterior surface of the patella and the plastic ring to the posterior surface of the implant. Use the clamp to apply a significant amount of pressure to the implant to fully seat the implant on the patellar surface (Figure 170). Remove excess cement.

ⓘ **Note:** If the implant post begins to engage at an angle, the implant should be removed and repositioned perpendicular to the resected surface. Insert the patella again and reclamp, applying an even distribution of pressure on the patellar surface.

NexGen All-Polyethylene Patella

Center the appropriate patellar drill guide over the patella with the handle on the medial side of the patella and perpendicular to the tendon. Holding the drill guide firmly in place, drill the three peg holes using the patellar/femoral drill bit (Figure 171).

Apply cement to the anterior surface and pegs of the patellar component while in a doughy consistency. Locate the drilled peg holes and use the patellar clamp to insert and secure the patella in place. Fully open the jaws of the clamp and align the teeth to the anterior surface of the patella and the plastic ring to the posterior surface of the implant. Use the clamp to apply a significant amount of pressure to the implant to fully seat the implant on the patellar surface. Remove excess cement.

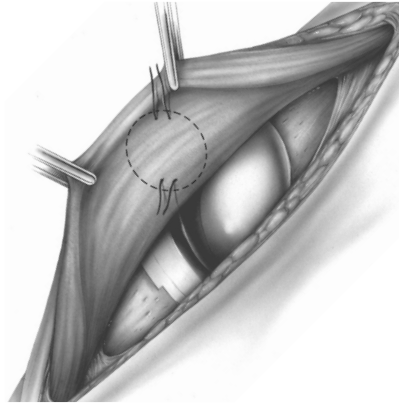

Figure 172

Augmentation Patella

Component Size Selection and Bone Preparation

Use a caliper to determine the thickness of the remaining patellar bone stock. The augmentation patella may be used if the remaining patella is less than 10 mm thick and patellar resurfacing with a standard implant is not feasible.

Note: Determine position, size, tilt, and depth of the augmentation patella base before reaming.

Use a spherical reamer to prepare the patellar bone bed. Select the reamer size according to the anticipated size of the implant base, as shown in this table.

Augmentation Patella	
Reamer Diameter	Overall Thickness
Medium, 52 mm	Medium, 19.5 mm
Medium, 38 mm	Medium, 22 mm
Large, 62 mm	Large, 19 mm
Large, 44 mm	Large, 22 mm

Trial Reduction

Select the appropriate size augmentation patella provisional and secure it with sutures in several places to the patellar tendon. Sutures provide stability during the trial reduction. With the joint reduced, ensure that the augmentation patella provisional easily engages the trochlear groove of the femoral component at 25° of flexion. When the proper position and orientation have been established, clamp the patella and mark the component position with a skin marker or cautery (Figure 172).

Securing the Augmentation Patella Base

Apply an adequate amount of bone cement to the anterior aspect (Trabecular Metal-dome shape) of the augmentation patella base. Then, place the device against the remaining patella bone stock and clamp until the cement is fully cured.

Suture the augmentation patella base to the extensor tendon. The holes in the augmentation patella base are chamfered to minimize the potential for abrasion of the sutures. Pass the sutures through the holes in the titanium ring, and tie the sutures on the posterior aspect of the augmentation patella base, as shown. If necessary, use a 1/16 in. (or 1 mm) drill to create holes in the native patella. Often, the patella is thin enough to permit placement of a suture without drilling.

Note: Components are indicated for use with bone cement in the United States.

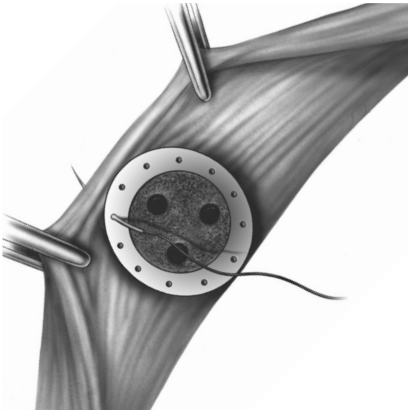

Figure 173

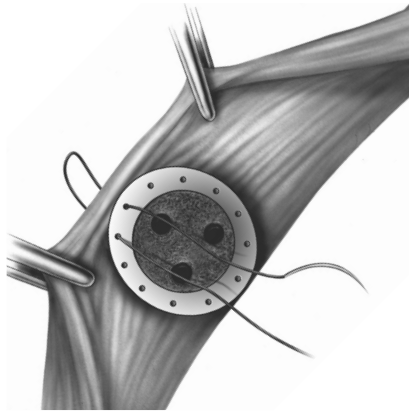

Figure 174

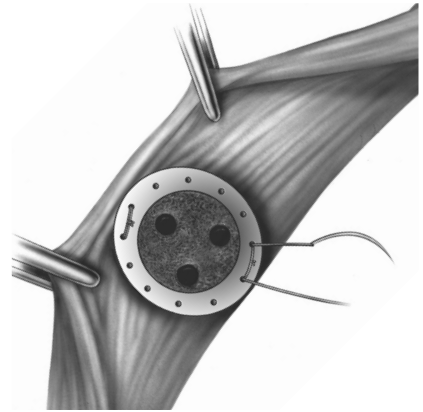

Figure 175

Securing the Augmentation Patella Base (cont.)

Use an interrupted suture pattern. Insert a #2 nonabsorbable suture through a hole on the posterior surface of the titanium ring (Figure 173). Bring the needle from the anterior surface back through an adjacent hole and cut the suture (Figure 174). Repeat the procedure, passing a second suture through the same set of holes and cutting the suture. Then tie two independent knots.

ⓘ Note: This can also be accomplished by doubling the suture through the eye of the needle and making one pass.

Tie the knots on the posterior surface of the patella. Repeat the same steps in two holes on the side opposite the completed suture (Figure 175). Alternating sutures on opposite sides helps ensure proper implant position and soft tissue balance. The augmentation patellar clamp can be used to hold the patella and augment while suturing.

ⓘ Note: Tight sutures on the base can compromise circulation. After the tourniquet is released, check the soft tissues to be sure they return to their normal color. If not, the sutures may need to be replaced with looser knots tied around the base.

Cementing the All-Polyethylene Patella

At the surgeon's discretion, implant position can be confirmed with an intraoperative radiograph.

Perform an additional trial reduction using the all-polyethylene patellar provisional placed onto the secure augmentation patella base. Select the all-polyethylene patella that will completely cover the underlying base and suture ring. Apply bone cement in its doughy state to the augmentation patella base and post holes, completely covering the suture ring. It is necessary to completely fill the space between the all-polyethylene patella and the suture ring, so the sutures are protected and the all-polyethylene patella is supported appropriately. Align the pegs of the all-polyethylene patella with the holes in the augmentation patella base and assemble the two together. Use the augmentation patellar clamp to clamp the patella, and remove excess cement. Allow the cement to fully cure before removing the clamp.

After the cement has hardened, observe patellar tracking through the full range of knee motion.

Trial Reduction and Implantation

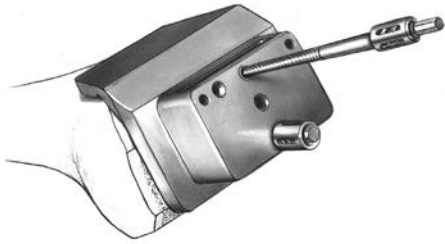

Figure 176

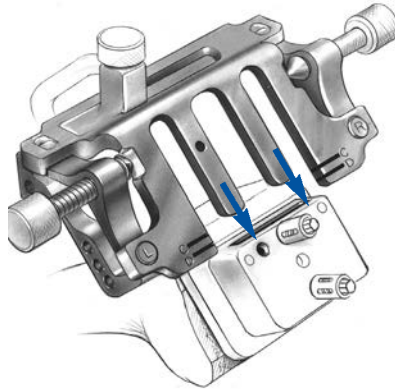

Figure 177

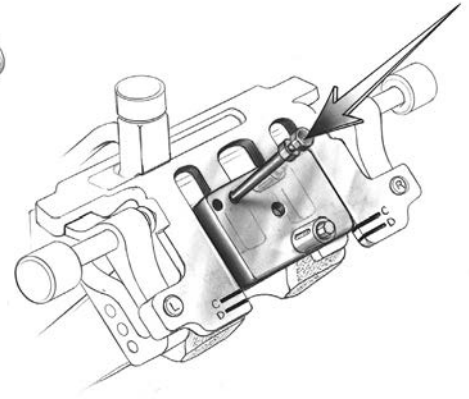

Figure 178

Trial Reduction

Insert the femoral provisional, patellar provisional, and the correct size tibial sizing plate if using the four-pegged tibial component or the correct size stemmed tibial provisional if using the stemmed tibial component. Remember that at least one color designation on the tibial provisional should match one of the color designations listed on the femoral provisional, and this color and size designation must be the same color and size of the bearing family being used. If three of a kind is not obtainable, the incorrect tray size has been selected and another tray size and bearing family should be selected. Insert the proper height bearing provisional and check the range of motion and ligament stability. Perform any necessary soft tissue releases. The femoral extractor can be used to remove the femoral provisional.

Femoral Recutting/Downsizing

If the extension gap is less than the flexion gap, it may be necessary to resect more distal bone or downsize the femur.

For MICRO-MILL/5-in-1 Instrumentation

Select the proper recutting block and pin it to the distal femur with two silver spring pins (Figure 176). Ensure that the block is seated on the distal and anterior femur. Insert the proper femoral a/p placement guide, with femoral mounting bases attached, into the block (Figure 177). Place a pin through the positioning hole into the placement guide (Figure 178). Then pin the mounting bases to the femur as previously described. Once this is complete, proceed to the femoral resection step.

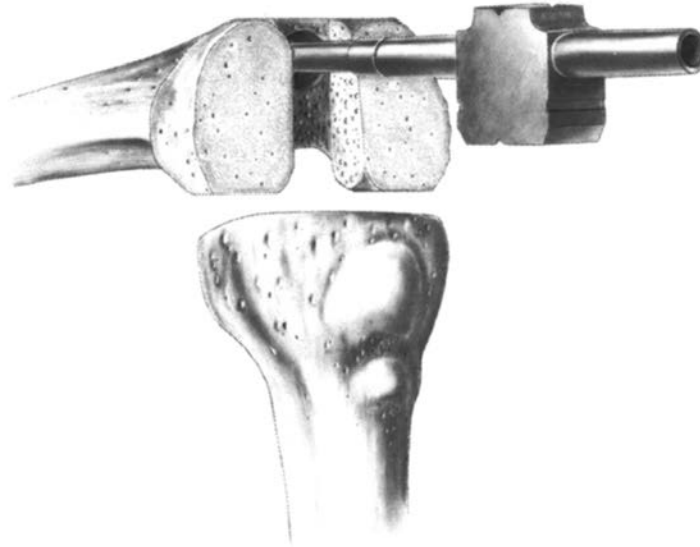

Figure 179

For Intramedullary, Epicondylar, or Multi-Reference 4-in-1 Femoral Instrumentation

An additional cut of 2 mm, 3 mm, or 5 mm can be made. Determine the desired additional cut by taking the difference between the spacer block thicknesses in flexion and extension. If full extension cannot be achieved with the 8 mm spacer block, estimate the amount of resection necessary using the minus spacer blocks (-2 mm, -3 mm, and -5 mm thicknesses). The additional resection indicated will bring the space up to 8 mm.

Insert two pins through the appropriate depth holes in the distal femoral recutting guide. Locate the guide so that the two depth pins are flush against the cut surface of the distal femur. Insert two holding pins to secure the instrument to the femur and recut the distal femur (Figure 179).

Remove the distal femoral recutting guide and use the appropriate spacer block to reassess the gaps.

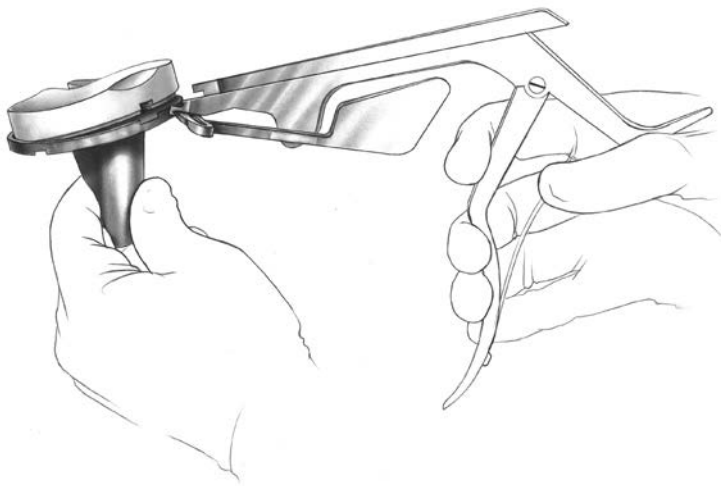

Figure 180

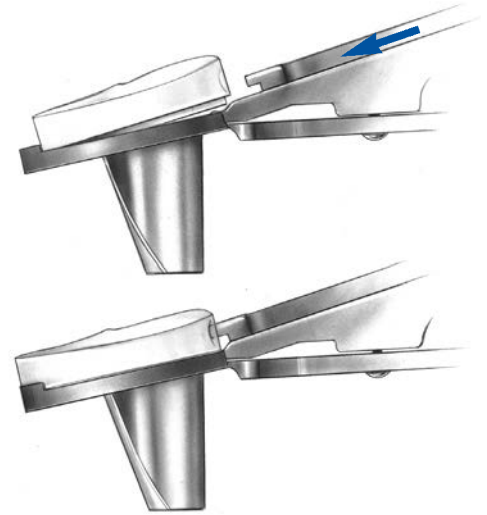

Figure 181

Component Implantation

After the implants have been chosen, make one last check to ensure that the femoral, tibial and bearing components match.

Bearing Insertion

The bearing Insertion Instrument applies both downward and rearward forces to aid in the insertion of the bearing onto the tibial tray. Push the lever on the instrument fully to either side. Place the bearing onto the implant tray, engaging the dovetails (Figure 180).

Steady the surface on the tray with one hand by applying downward pressure near the posterior cruciate cutout. Engage the hook on the insertion instrument with the mating slot in the front of the plate and close the lever with your index finger.

This should lock the insertion instrument to the tray. Squeeze the handles of the insertion instrument to seat the bearing (Figure 181). Open the lever and remove the insertion instrument. Only insert a bearing once. Never reinsert the same bearing onto a tibial tray.

All content herein is protected by copyright, trademarks and other intellectual property rights, as applicable, owned by or licensed to Zimmer Biomet or its affiliates unless otherwise indicated, and must not be redistributed, duplicated or disclosed, in whole or in part, without the express written consent of Zimmer Biomet.

This material is intended for health care professionals. Distribution to any other recipient is prohibited.

Zimmer Biomet does not practice medicine. This technique was developed in conjunction with health care professionals. This document is intended for surgeons and is not intended for laypersons. Each surgeon should exercise his or her own independent judgment in the diagnosis and treatment of an individual patient, and this information does not purport to replace the comprehensive training surgeons have received. As with all surgical procedures, the technique used in each case will depend on the surgeon's medical judgment as the best treatment for each patient. Results will vary based on health, weight, activity and other variables. Not all patients are candidates for this product and/or procedure. Caution: Federal (USA) law restricts this device to sale by or on the order of a surgeon.

For product information, including indications, contraindications, warnings, precautions, potential adverse effects and patient counseling information, see the package insert and zimmerbiomet.com.

Check for country product clearance and reference product specific instructions for use. Not for distribution in France.

© 2017 Zimmer Biomet



1391.1-GLBL-en-REV0517



Legal Manufacturer
Zimmer, Inc.
1800 West Center Street
Warsaw, Indiana 46580
USA
zimmerbiomet.com



CE mark on a surgical technique is not valid unless there is a CE mark on the product label.